



# GGB METAFRAM RANGE

**SELF-LUBRICATING SINTER BRONZE  
AND SINTER IRON BEARING SOLUTIONS**



# PUSHING BOUNDARIES TO CO-CREATE A HIGHER QUALITY OF LIFE

---

GGB helps create a world of motion with minimal frictional loss through plain bearing and surface engineering technologies. With R&D, testing and production facilities in the United States, Germany, France, Brazil, Slovakia and China, GGB partners with customers worldwide on customized tribological design solutions that are efficient and environmentally sustainable. GGB's engineers bring their expertise and passion for tribology to a wide range of industries, including automotive, aerospace and industrial manufacturing. To learn more about tribology for surface engineering from GGB, visit [www.ggbearings.com](http://www.ggbearings.com).

Our products are used in tens of thousands of critical applications every day on our planet. It is always our goal to provide superior, high-quality solutions for our customers' needs, no matter where those demands take our products. From space vehicles to golf carts and virtually everything in between; we offer the industry's most extensive range of high performance, maintenance-free bearing solutions for a multitude of applications:

- [Aerospace](#)
- [Agricultural](#)
- [Automotive](#)
- [Construction](#)
- [E-Mobility](#)
- [Energy](#)
- [Fluid Power](#)
- [Industrial](#)
- [Medical](#)
- [Mining](#)
- [Oil & Gas](#)
- [Primary Metals](#)
- [Railway](#)
- [Recreation](#)

# The GGB Advantage

---



## LOWER SYSTEM COST

GGB bearings reduce shaft costs by eliminating the need for hardening and machining grease paths. Their compact, one-piece construction provides space and weight savings and simplifies assembly.



## LOW-FRICTION, HIGH WEAR RESISTANCE

Low coefficients of friction eliminate the need for lubrication, while providing smooth operation, reducing wear and extending service life. Low-friction also eliminates the effects of stick-slip or "stiction" during start up.



## MAINTENANCE-FREE

GGB bearings are self-lubricating, making them ideal for applications requiring long bearing life without continuous maintenance, as well as operating conditions with inadequate or no lubrication.



## ENVIRONMENTAL

Greaseless, lead-free GGB bearings comply with increasingly stringent environmental regulations such as the EU RoHS directive restricting the use of hazardous substances in certain types of electrical and electronic equipment.



## CUSTOMER SUPPORT

GGB's flexible production platform and extensive supply network assure quick turnaround and timely deliveries. In addition, we offer local applications engineering and technical support.

# The Highest Standards in Quality

---



## SAFETY

Our deep-rooted culture of safety places a relentless focus on creating a secure, healthy work environment for all. As one of our core values, safety is essential for us to achieve our goal of having the safest employees in the industry.



## EXCELLENCE

Our world-class manufacturing plants in the United States, Brazil, China, Germany, France, and Slovakia are certified in quality and excellence according to ISO 9001, IATF 16949, ISO 14001, ISO 45001 and AS9100D/EN9100. This allows us to access the industry's best practices while aligning our management system with global standards.

For a complete listing of our certifications, please visit our website:

[www.ggbearings.com/en/company/certificates](http://www.ggbearings.com/en/company/certificates)



## RESPECT

Our teams work together with mutual respect regardless of background, nationality, or function, embracing the diversity of people and learning from one another - after all, with respect comes both individual and group growth.

## **TIMKEN AND GGB: EXPONENTIAL EXPERTISE AND INNOVATION**

Timken has completed 24 acquisitions since 2010 to advance its engineered bearings and industrial motion expertise. The latest, GGB, provides additional technical solutions that strengthen Timken's position in key strategic markets.

At GGB, engineers apply specialized knowledge in material science and tribology to innovate polymer coatings and plain bearing solutions for industrial applications, including pumps and compressors, HVAC, off-highway, energy, material handling and aerospace. With its acquisition of GGB, Timken diversifies its technical expertise and global leadership in highly engineered bearings — giving customers access to more custom bearing solutions across more markets.

### **Exponential innovation for shifting design trends**

Andreas Roellgen, executive vice president and president of the Engineered Bearings group, said the GGB acquisition builds on Timken's "advanced coating technologies and customized solutions for customers' specific needs in fragmented markets". While every acquisition is about adding value for customers, the more synergies there are, the greater the potential.

"Timken has very strong capabilities in material science, surface engineering and tribology — specific to steel-made bearings with rolling elements," said Roellgen. "GGB builds on strengthening knowledge beyond steel-bearing competencies in all three areas that help address emerging technical trends for our customers."

Two such trends are light-weighting and downsizing in applications like electric vehicles and wind energy. GGB plain bearing solutions help with this by using a wide range of materials like polymer coatings, engineered plastics, fiber-reinforced composites and bimetals.

In many cases, the two companies engineer adjacent, ultra-high-performance solutions for the same customers and equipment.

For example, the Curiosity rover has been operating on Mars for 10+ years and depends on GGB self-lubricating metal-polymer bushings to help drill for rock samples. Also onboard are two ¼ inch (6.35 mm) Timken bearings that run a vacuum pump in support of the rover's analytical equipment. Essentially, GGB helps gather the samples, and Timken makes it possible to learn about them. Both are crucial to mission success.

### **Shared legacy, complementary products**

GGB was founded in 1899, the same year Timken began producing its first patented tapered roller bearing. Also similar to Timken, GGB demonstrated early leadership in key markets, inventing the first self-lubricated metal-polymer bearing, and they are recognized for their excellence in application engineering.

Chris Small, president, GGB, added that this is what sets GGB apart in the global plain bearings market.

"It's extremely competitive, but we're able to win customers because our strong application engineering capabilities and our legacy of material science innovations," he said. "Collaborating with customers, designing into their applications and solving their most critical problems brings so much loyalty."

And like Timken, GGB has a global manufacturing footprint committed to safety, quality and efficiency, in support of an ever-evolving product line.

"GGB will have a noteworthy impact due to its size and scope, Roellgen said. They have capabilities and products new to our customers. We have the channel access to get them into new market spaces. From a customer value creation standpoint, it's quite exciting."

# Table of Contents

---

<b>1</b>	<b>Introduction</b>	<b>6</b>	<b>8</b>	<b>Standard Dimensions</b>	<b>21</b>
<b>2</b>	<b>Applications</b>	<b>7</b>	8.1	Bronze based GGB-BP25 Cylindrical Bearings	21
2.1	Characteristics and Benefits of GGB Sinter Bearings	7	8.2	Iron based GGB-FP20 Cylindrical Bearings	22
2.2	Possible Applications	8	8.3	Bronze based GGB-BP25 Flanged Bearings	23
2.3	Available Designs	9	8.4	Iron based GGB-FP20 Flanged Bearings	24
<b>3</b>	<b>Material Properties</b>	<b>9</b>	8.5	Cylindrical Blanks	24
3.1	Material Structure	9	8.6	Solid Rod Blanks	25
3.2	Grade Selection	10	8.7	Spherical Bearings	25
3.3	Bronze based and Iron based Grades	10		<b>Bearing Application Data Sheet</b>	<b>26</b>
<b>4</b>	<b>Lubrication</b>	<b>11</b>		<b>Product Information</b>	<b>27</b>
4.1	Lubricant Selection	11			
4.2	Principles of Lubrication	13			
<b>5</b>	<b>Dimensions and Tolerances</b>	<b>15</b>			
<b>6</b>	<b>Bearing Installation</b>	<b>16</b>			
<b>7</b>	<b>Machining</b>	<b>18</b>			
7.1	Machining of Self-lubricating Blanks	18			
7.2	De-impregnation and Re-impregnation of Self-lubricating Bearings	20			

# 1 Introduction

---

The more and more demanding specifications of today's high performance equipment and systems require that the bearings operate not only under severe working conditions with minimal or no maintenance but that they also offer increased reliability and durability with lower operating costs.

Self-lubricating METAFRAM® sinter bronze and sinter iron bearings are designed for applications with high sliding speeds, requiring a low coefficient of friction, good corrosive or seizure resistance and suited to frequent stop starts, as well as for applications for which customary lubrication is not possible.

Furthermore, these bearings can replace already installed traditional lubricated bearings and offer solutions where customary lubrication is not possible.

With more than 100 years of experience and expertise in tribology, GGB offers, along with the widest range of lubricated and self-lubricating bearing products, a comprehensive technical and application engineering knowledge.

In this respect, our Application Engineers can assist you in:

- Choosing the right type of plain bearing for your application
- Design of the bearing according to standard dimensions or to customer specific requirements
- Establishing a life time estimate
- Assembly and installation recommendations

Thanks to our global production and supply network, we are able to offer customers throughout the world the industry's most extensive range of self-lubricating and prelubricated plain bearings for literally thousands of applications in scores of industries.

As a reliable supplier with flexible manufacturing, we can respond quickly to customer needs with either standard or customized products.

Our advanced R&D and testing facilities help us deliver comprehensive solutions and assure their performance, reliability and cost-effectiveness.

Our high performance bearing specialists have the experience and expertise to provide innovative solutions to even the most challenging applications.

# 2 Applications

---

The GGB sinter bearings from the METAFRAM® range are recommended for the following movements:

- Rotation
- Oscillation
- Linear

Other special material grades are available for specific requirements, for example:

- Higher speeds
- Higher loads

For more demanding requirements with lower or higher temperatures, increased speeds or loads, bearings can be impregnated with appropriate lubricants.

## 2.1 CHARACTERISTICS AND BENEFITS OF GGB SINTER BEARINGS

Self-lubricating sinter bearings offer the following benefits depending on the grade of the metallic alloy and on the type of lubricant:

### Performance

An extremely wide range of operating loads, speeds and temperatures:

- Dynamic loads from 6 to 75 MPa
- Linear speeds up to 8 m/s
- Operating temperatures from - 180°C to + 300°C

### Suitable for use in a wide range of environments

- Marine environment
- Radio-active environments
- Contact with corrosive liquids or substances incompatible with oils
- Food preparation

### Reduce of design and ownership costs

- Maintenance-free operation
- Lower cost compared to cast metal and machined bearings
- Complex designs and forms possible
- High dimensional accuracy
- Excellent surface finish
- Reduced weight compared to similar non-porous components

### Safety

- Permanent oil film lubrication
- Low friction factor
- Quiet operation
- Good operation at low speed
- Corrosion resistance

## 2.2 POSSIBLE APPLICATIONS

### Industrial:

General assembly machinery, industrial vehicles, automation, farm machinery, sewing machines, bottling machines, key duplicating machines, electrical switchgears, mobility, toys, etc.

### Household appliances:

Washing machines, fans, woodworking machines, vacuum cleaners, extractor fans, depilators, coffee machines, juicers, roisserie, handtools, air conditioning, boilers, etc.

### Home appliances:

Lawnmowers, roller shutters, office swivel chairs, locks, garage doors, awnings, sliding windows, hinges, furniture, gardening, etc.

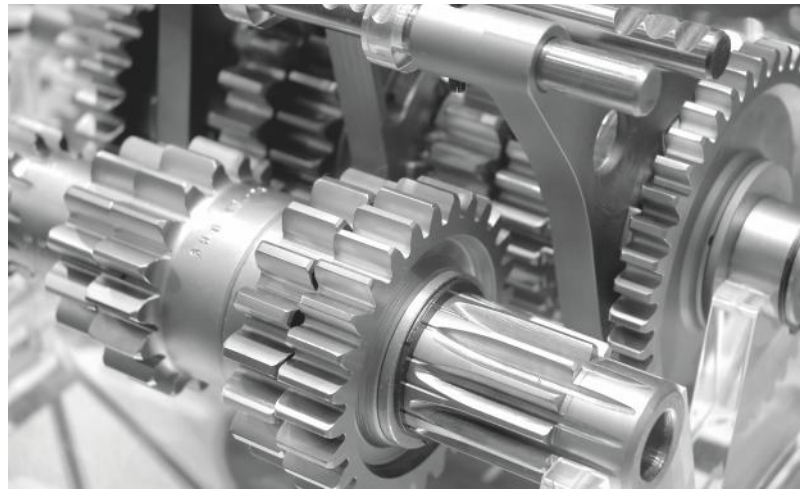

## 2.3 AVAILABLE DESIGNS

### Standard products

- Cylindrical plain bearings
- Flanged plain bearings
- Hollow and solid rod blanks for machining



### Special parts on request

- Modified standard sizes
- Customized designs
- Sphericals



# 3 Material Properties

## 3.1 MATERIAL STRUCTURE

Sinter bronze and sinter iron self-lubricating bearings are made of two components which have different functions:

- The metallic alloy structure which supports and transfers the mechanical loads
- The liquid or solid lubricant which separates the two surfaces in relative motion and to reduce friction

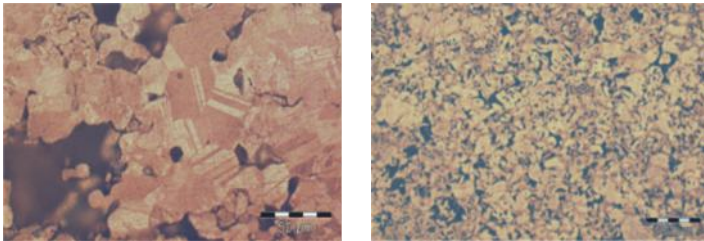

Fig. 1: Microsection of Sinter bronze (left) and Sinter iron

## 3.2 GRADE SELECTION

The metallic structure of the self-lubricating bearing can be made from a wide range of bronze or iron based alloys. To select the proper grade for a given application, it is necessary to check the maximum values of the material characteristics in comparison with:

- Shaft linear speed - v
- Applied load - p
- pU (load x speed) factor
- Shaft hardness and surface roughness and other parameters such as working temperature and type of lubrication, etc.

The following tables give the main physical and mechanical characteristics of GGB self-lubricating sinter bearings from the METAFRAM® range.

## 3.3 BRONZE BASED AND IRON BASED GRADES

STANDARD MATERIAL GRADES	UNITS	BRONZE GGB-BP25	IRON ALLOY GGB-FP20	IRON ALLOY GGB-S016 (blanks only)
Similar to AFNOR		FU-E10-62	FC10-U3-56	F50-U20-60
Similar to DIN 30910		Sint A50	Sint A10	N/A
Minimum density	g/cm <sup>3</sup>	6.2	5.6	6.0
Maximum load p	MPa	20.0	45.0	120.0
- static - dynamic		10.0	22.5	60.0
Maximum sliding speed v	m/s	6.0	4.0	0.3
Maximum pv factor	MPa x m/s	1.8	1.8	0.9
Operating temperatures	°C	- 5 / 90	- 5 / 90	0 / 105
Impregnation oil		MT100	MT100	METADOP
Minimum open porosity	%	23	20	16

Table 1: Standard material grades

## MATERIAL GRADE SELECTION

BRONZE GGB-BP25	IRON ALLOY GGB-FP20	IRON ALLOY GGB-S016
Good coefficient of friction	Recommended for medium or low speeds	Recommended for medium or low speeds
Good corrosion resistance	Good bearing strength	Good bearing strength
Recommended for high speeds	Recommended for high loads	Recommended for very high loads
Shaft surface finish Ra ≤ 0.6 µm	Shaft surface finish Ra ≤ 0.2 µm	Shaft surface finish Ra ≤ 0.2 µm
Shaft hardness HB > 240	Shaft hardness HB > 355	Shaft hardness HB > 355

Table 2: Material grade selection

# 4 Lubrication

## 4.1 LUBRICANT SELECTION

Significant development and improvement of lubricants allow the use of METAFRAM® bearings in more and more applications and to comply with a wide range of working conditions in terms of temperature range and environment.

### Under high loads

The use of lubricants using MoS<sub>2</sub> additives such as METADOP (Shell OM460 + MoS<sub>2</sub>) is recommended.

### Temperature range

These lubricants are suitable for a temperature range from - 40°C to 150°C.

Lubricants offering a wider temperature range are available on request.

### Environment

The lubricant PE1152 is compliant with FDA (Food and Drug Administration) regulation.

## IMPREGNATION LUBRICANTS

PRODUCER	DESIGNATION	TYPE	POUR POINT °C	FLASH POINT °C	VISCOSITY cSt		TEMPERATURE RANGE °C	
					at 40°C	at 100°C		
Shell	MT100	Mineral	- 9	255	100	11.5	- 5	90
Lubrilog	PE1116	Synthetic	- 50	255	65	9.5	- 40	150
Shell	OM460	High pressure	- 12	238	460	29	0	105
Lubrilog	PE1152	FDA	- 18	252	68	9	- 18	120

Table 3: most common oils. More oil grades are available on request for specific applications.  
For further information please contact our application engineering department.

## CHEMICAL AND PHYSICAL CHARACTERISTICS OF OIL

Lubricants based on mineral oils comprise of a organic and inorganic compounds and their physical and chemical characteristics vary considerably.

A good understanding of the main characteristics hereafter mentioned is necessary to study difficult lubrication cases. The stability under oxidation and the viscosity are particularly important.

### Stability under oxidation

Oxidation is a chemical reaction resulting from the combination of the oxygen contained in the air and with the mineral oil. The oxidized compounds can have an adverse effect on bearing operation. If soluble, they transform into acids and can generate corrosion on the metallic sliding counter face of the bearing. They can also form a resilient varnish which fills the the bearing porosities.

**Acidity**

Low acidity of the mineral oils is acceptable.

However, the acidity will increase when running at high temperature for long periods of time due to oxidation.

**Viscosity**

The viscosity of a liquid can be defined as a resistance to pouring, or as a measure of the friction between the molecules of the liquid in relative motion.

In the oil industry, the two common measurements are the kinematic viscosity in centistokes (cSt) or in Engler degrees.

**Viscosity index (VI)**

An increase in temperature leads to weaker intermolecular links inside the fluid and a decrease in viscosity. The viscosity index indicates the evolution of the viscosity with temperature. The higher the index, the less sensitive is the oil to increases in temperature.

**Pour point**

A mineral oil does not change directly from a liquid state to a solid state when it is cooled down. It exhibits a plastic intermediate phase due to the crystallization of paraffin and the freezing of the different elements.

The pour point is approximately the lowest temperature at which the pouring of the liquid can be observed.



## 4.2 PRINCIPLES OF LUBRICATION

### Hydrodynamic Lubrication (high Speed - low Load)

#### Stationary position (1)

- The shaft is in contact with the bearing
- An oil meniscus is present at the contact point resulting from capillary forces.
- This oil meniscus assists in instant lubrication during startup.

#### Rotating shaft (2)

- Oil is drawn out of the bearing in the upper suction zone.
- Oil is driven around by the rotation of the shaft and forms an oil wedge which produces the necessary pressure to lift the shaft.
- Part of the circulating oil is forced, under the action of the pressure, in the pores of the bearing.

#### After operation (3)

The oil is reabsorbed by the porous bearing, under the action of capillary forces.

The oil meniscus remains at the contact point ready for instant lubrication startup.

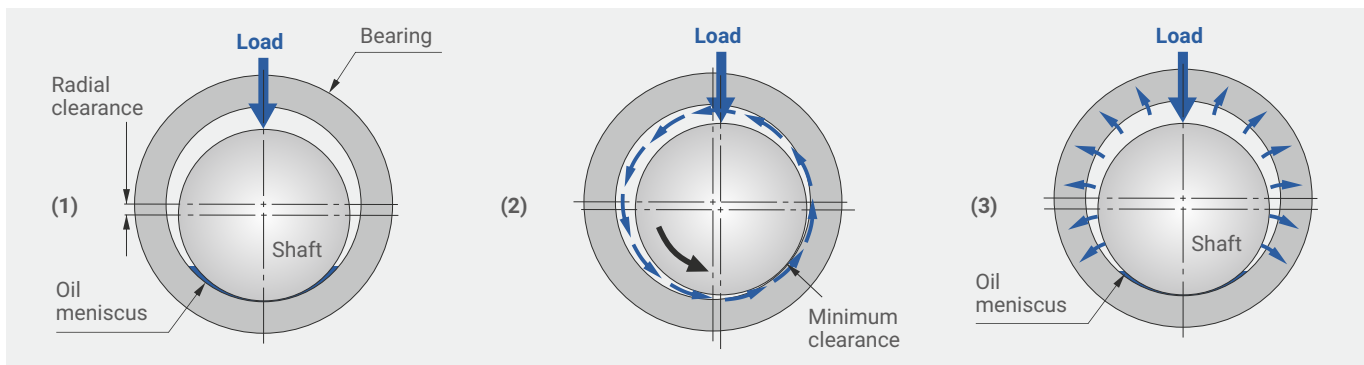

## BOUNDARY LUBRICATION (LOW SPEED - HIGH LOAD)

The features of this lubrication mode are as follows:

- Lubrication is provided by a lubricant film composed of molecular layers, with a strong force of adhesion to the surface and a low shear strength.
- Presence of metallic contact between the friction surfaces. Surface wear can be minimized using extreme pressure oils (eg. Shell OM460).

## SOLID LUBRICANTS

In certain applications where the use of oil is not permitted (water presence, galvanic issues etc.) it is recommended to use solid lubricants such as molybdenum disulfide MoS<sub>2</sub>, graphite Cg or fluoropolymers PTFE.

DESIGNATION	max. SPEED m/s	max. LOAD MPa	pU LOAD x SPEED MPa x m/s	TEMPERATURE RANGE °C	LOAD v=0 MPa	SHAFT Ra max µm   HB min.	
GGB-BP25 + PTFE	1.0	10.0	0.3	- 180 / 180	20	0.3	240
GGB-FP20 + PTFE	1.0	22.5	0.3	- 180 / 180	45	0.3	300
GGB-BP25 + MoS <sub>2</sub>	0.1	10.0	0.1	- 180 / 180	20	0.3	355
GGB-FP20 + MoS <sub>2</sub>	0.1	22.5	0.1	- 180 / 300	45	0.3	355

Table 4: Grades proposed with solid lubricants.

# 5 Dimensions and Tolerances

The following tables indicate the size of the cylindrical or flanged bearings, and give the tolerances of the main dimensions.

In case reduced tolerances are required due to working requirements such as noise or vibration reduction, please contact your local GGB representative.

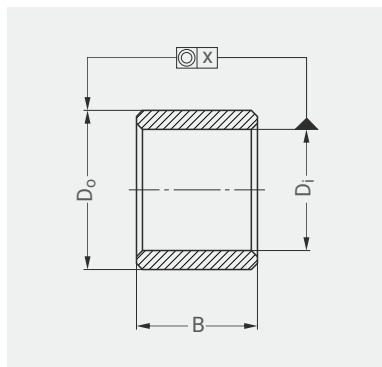

CYLINDRICAL BEARINGS		TOLERANCE $D_i$	TOLERANCE $D_o$	TOLERANCE B	TOLERANCE X
$B/D_o < 1.5$ and $B/S_3 < 15$	$D < 6$	IT6	IT6	IT12	IT9
	$6 < D \leq 10$	IT6	IT6		
	$10 < D \leq 18$	IT6	IT6		
	$18 < D \leq 30$	IT6	IT7		
$1.5 < B < 2$ and $B/S_3 < 20$	$D < 6$	IT6	IT6	IT12	IT9
	$6 < D \leq 10$	IT6	IT6		
	$10 < D \leq 18$	IT6	IT7		
	$18 < D \leq 30$	IT7	IT7		
	$30 < D \leq 50$	IT7	IT7	IT13	

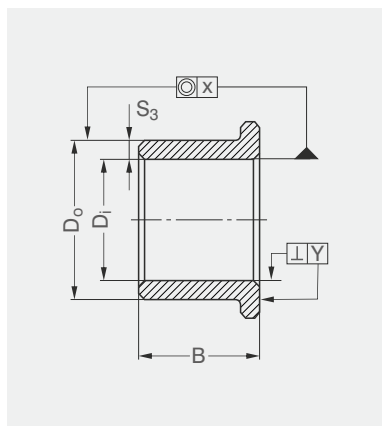

FLANGED BEARINGS		TOLERANCE $D_i$	TOLERANCE $D_o$	TOLERANCE B	TOLERANCE X	Tolerance Y
$B/D_o < 0.5$ and $B/S_3 < 5$	$D < 10$	IT6	IT6	IT12	IT9	0.05
	$10 < D \leq 18$	IT6	IT6			
	$18 < D \leq 30$	IT6	IT6			
$0.5 < B$ $D_o < 1$ and $B/S_3 < 10$	$D < 10$	IT6	IT6	IT12	IT9	0.05
	$10 < D \leq 18$	IT6	IT7			
	$18 < D \leq 30$	IT7	IT7			
$1 < B$ $D_o < 2$ and $B/S_3 < 15$	$D < 10$	IT6	IT7	IT12	IT9	0.05
	$10 < D \leq 18$	IT7	IT7			
	$18 < D \leq 30$	IT7	IT8			
	$30 < D \leq 50$	IT8	IT8	IT13		0.07

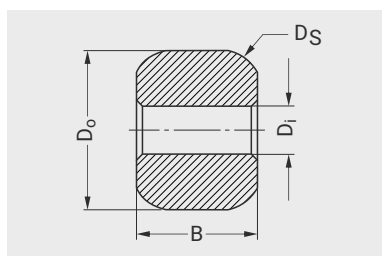

SPHERICAL BEARINGS	TOLERANCE $D_i$	TOLERANCE $D_s$	TOLERANCE $D_o$	TOLERANCE B	CONCENTRICITY $D_i / D_o$
	IT6	+/- 0.05	+/- 0.2	+/- 0.1	0.05

Minimum weight per bearing: 0.2 g Minimum thickness: 1 mm

B = bearing length (mm)  $D_i$  = bearing bore (mm)

$D_o$  = bearing outer  $\varnothing$  (mm)  $D_s$  = sphere  $\varnothing$  (mm)  $S_3$  = wall thickness:  $\frac{D_o - D_i}{2}$  (mm)

Flange tolerances: Flange outside diameter: js13 - Flange thickness: js14

## SURFACE ROUGHNESS

The surface roughness  $R_a$  of the inside diameter of a self-lubricated sinter bearing is between 1.2  $\mu\text{m}$  and 3.2  $\mu\text{m}$ , depending on the powder type (grain size) and on the density.

For standard grades (GGB-BP25, GGB-FP20), the surface roughness is between 2.5  $\mu\text{m}$  and 3.2  $\mu\text{m}$ .

# 6 Bearing Installation

---

## **Fitting with a stepped mandrel** (Ground carbon steel – Surface finish: polished - Hardness > 60 RC)

The bearing is inserted into the housing with a press, using a stepped mandrel made to the recommended tolerances in order to avoid damage to the bearing and to obtain:

- A good guidance of the bearing which must be square to the housing
- The correct tolerance of the inside diameter of the bearing after assembly

## **Insertion forces**

Estimated value with m6 mandrel, H7 housing with  $R_a < 3.2 \mu\text{m}$  and housing considered as rigid\*:  
10 MPa (surface equal to  $D \times B$  of the bearing)

\*Housing considered as rigid: steel or cast iron housing with thickness at least 3 times the wall thickness of the bearing.

## **Steel housing** (rigid)

The inner diameter tolerances of the assembled bearing and the final tolerances of the inner diameter of the bearing are determined assuming a rigid housing made of steel or eventually in cast iron.

## **Housing made of light alloys** (aluminium, zamak etc.)

The interference fit is to be increased to compensate for the deformation of the housing. Tests are required to define the tolerances of the housing.

In certain conditions, housing ID / mandrel OD fits of J7 / s7 or K7 / s7 enable a H7 tolerance of the inner diameter of the bearing after assembly.

In the case of an assembly into light alloys and to minimize the risks due to creep deformation, it is sometimes necessary to design special shapes.

## **Shafts recommendations**

Mechanical recommendations of steel shaft according to bearing grades:

For GGB-BP25 Sinter Bronze bearings:

- Steel hardness HB > 240
- Surface roughness  $R_a < 0.6 \mu\text{m}$

For GGB-FP20 Sinter Iron bearings:

- Steel hardness HB > 355
- Surface roughness  $R_a < 0.2 \mu\text{m}$

### Mandrel

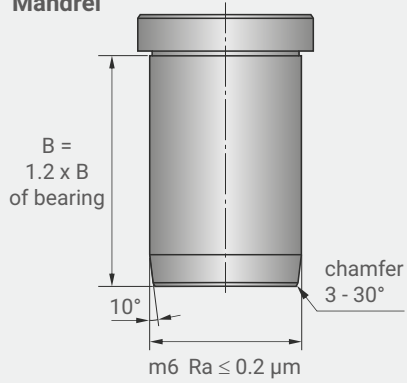

### Bearing in free state (Standard bearings)

Tolerance  $D_i$ : F7 (for  $D_i > 50$  mm: F8)

Tolerance  $D_o$ : s7 (for  $D_i > 50$  mm: s8)

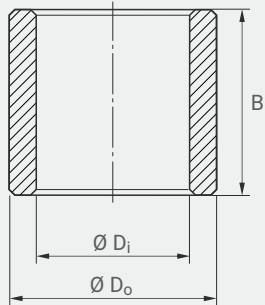

### Steel housing (rigid)

Tolerance  $D_{\text{housing}}$ : H7

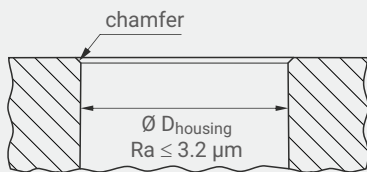

### Bearing after assembly (Standard bearings)

Tolerance  $D_i$ : H7 for  $D_i > 50$  mm: H8

Tolerance  $D_i$ : H8 for flanged bearings

Tolerance  $D_o$ : H8

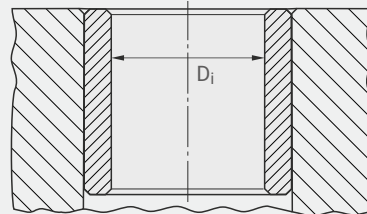

### Shafts recommendations

Tolerance D: f7

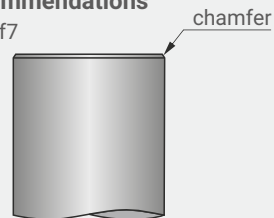

# 7 Machining

## 7.1 MACHINING OF SELF-LUBRICATING BLANKS

The sinter materials can be machined under the same conditions as for the corresponding solid metals. However, to protect the integrity of the porosities on the sliding surfaces (inner diameter or flange faces) it is recommended to apply the following specific machining conditions:

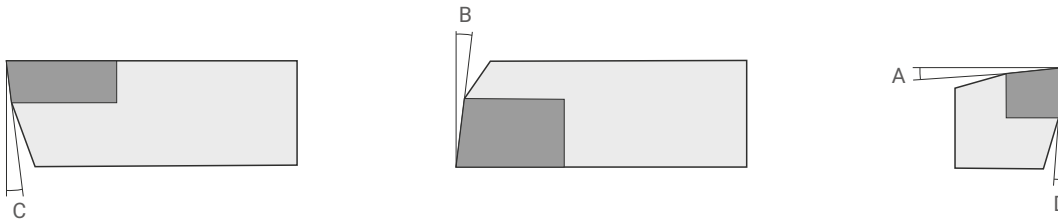

### MACHING CONDITIONS FOR BRONZE BASED GGB-BP25

ANGLE	ROUGH / FINISH		ROUGH	FINISH
A	0 - 3°	Tool grade	K10 / K20	K10 / K20
B	5 - 7°	Cutting speed (m/min)	120 - 200	140 - 200
C	5 - 7°	Feed rate (mm/rotation)	0.1 - 0.2	0.1 max
D	5 - 7°	Feed (mm)	≤ 1.0	0.1 - 0.4

### MACHING CONDITIONS FOR IRON BASED GGB-FP20 AND GGB-S016

ANGLE	ROUGH	FINISH		ROUGH	FINISH
A	3 - 7°	7 - 10	Tool grade	K10 / K20	K10 5015 (cermet*)
B	5°	10	Cutting speed (m/min)	140	160 200 - 250
C	5 - 7°	12 - 15	Feed rate (mm/rotation)	0.2 - 0.3	0.035 0.035 - 0.06
D	5 - 7°	12 - 15	Feed (mm)	1 - 5	0.3 - 0.5 0.3 - 0.5

\* For increased productivity

## TURNING

### Fixing

To avoid any deformation, especially for thin wall bearings, the machining of the inner diameters will be performed by fixing the part between grip clamps or soft jaws. For machining the outer diameter, the blanks must be fixed either on cantilevered mandrels or between centers mandrels (mandrel conicity 0.01%).

### Facing and chamfering

After machining the faces with a very sharp tool, it is recommended to cut an internal and external chamfer in the range of 0.5 mm at 45°.

## DRILLING

When drilling through the bore, it is necessary to slow down the feed rate at the time of the release.

**Bronze based GGB-BP25:** no specific requirement.

**Iron based GGB-FP20:** HSS drill with 5% cobalt, with cutting speed between 25 and 30 m/min and feed rate of 0.1 to 0.3 mm/min.

## TAPPING

**Bronze based GGB-BP25:** no specific requirement.

**Iron based GGB-FP20:** nitrided taps with 5% cobalt, with cutting speed between 8 and 12 m/min.

## GRINDING

This machining type is not recommended for the finishing of the inner diameters. The reason is that the abrasive particles coming from the grinding wheels will be embedded in the sliding surface porosities and will accelerate the wear of the surfaces in motion.

## CUTTING OIL

The use of cutting oil is not necessary for the machining of the METAFRAM® blanks as the blank is impregnated with oil and therefore oil is present in the porosities of the sinter material. However, if the parts need to be cooled down, especially in the case of machining of high volumes, it is recommended to use the same oil as the one initially used for impregnation, or to use an air jet.

Any other cooling fluid should be avoided as it would risk to be incompatible with the original impregnation oil.

## RE-IMPREGNATION AFTER USE

All standard METAFRAM® blanks are supplied impregnated with mineral oils with a viscosity index higher than 95 cSt.

- To eliminate chips and dust, quickly wash the part with a volatile solvent such as Heptane or Biosane ECO 60R, then dry.
- Depending on the volume immerse the bearing for one or two hours in an oil bath at a temperature between 60°C and 120°C, depending on the oil viscosity.

However, to compensate the loss of oil during machining and handling, a re-impregnation is mandatory according to the following process:

- Cool down the part in this bath for a perfect saturation of porosities. It is recommended to use the same oil as the one used originally for the impregnation, or otherwise, engine oil type SAE 30.

## IMPREGNATION OILS

When the linear speed of the shaft is higher than 0.3 m/s, the standard impregnation oil is Shell Turbo T100 with a viscosity index equal to 98 cSt.

For rotational speeds lower than 0.3 m/s, for linear or angular movements, specific impregnation can be made on request (extreme pressure oil, molybdenum disulfide additives).

## CONTROL OF SURFACE POROSITIES

In practice, it is accepted that any machining will slightly diminish the porosities of the sliding surfaces without impacting the performance of the self-lubricating material if the above machining instructions are respected. The control after machining of the residual porosities should be performed:

- Either by a comparative examination of the machined surface versus the non-machined surface under magnification.
- Or by a temperature increase of the machined part by 30°C on a heating source.

The large difference of coefficient of thermal expansion between the sinter metal and the impregnation oil generates the exudation of the lubricant.

The formation of a uniformly distributed oil film is the indication that the self-lubricating properties of the material are preserved.

## 7.2 DE-IMPREGNATION AND RE-IMPREGNATION OF SELF-LUBRICATING BEARINGS

### DE-IMPREGNATION

To de-impregnate a self-lubricating bearing, the process is the following:

- Degrease and wash in appropriate solvent
- Eliminate the lubricant in an apparatus such as Soxhlet or in a furnace heated around 400°C for 40 minutes under a neutral atmosphere such as N<sub>2</sub>, or with reducing agent such as N<sub>2</sub> + H<sub>2</sub>

### RE-IMPREGNATION

Simple method:

- Immerse during one hour the parts in an oil bath heated at a temperature between 60°C and 120°C, depending on oil viscosity.
- Let them cool down in an oil bath back to room temperature.
- Drain and dry the self-lubricating bearings.

The oil viscosity must be between 2 and 3 Engler degrees (10 to 20 cSt) at impregnation temperature.

# 8 Standard Dimensions

## 8.1 BRONZE BASED GGB-BP25 CYLINDRICAL BEARINGS

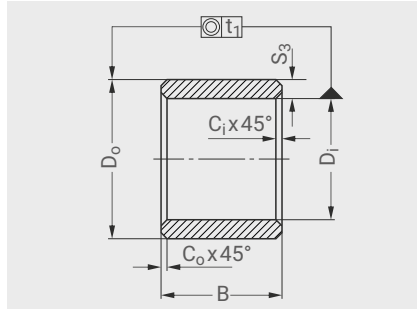

$t_1$  for  $D_i \leq 20 \text{ mm} = 50 \mu\text{m}$   
 $t_1$  for  $20 \text{ mm} < D_i \leq 35 \text{ mm} = 70 \mu\text{m}$   
 $t_1$  for  $D_i > 35 = 100 \mu\text{m}$   
 chamfers  $C = (0.1 \text{ to } 0.2) S_3$   
 minimum  $0.2 \text{ mm}$   
 $B > 10 \pm 1\%$   
 $B \leq 10 \pm 0.1 \text{ mm}$

INSIDE Ø $D_i$	OUTSIDE Ø $D_o$	LENGTH B
2 +16 +6	5 +31 +19	2 - 3
3 +16 +6	6 +31 +19	4 - 6 - 10
4 +22 +10	7 +38 +23	4 - 8 - 12
4 +22 +10	8 +38 +23	4 - 8 - 12
5 +22 +10	8 +38 +23	5 - 8 - 10 - 12 - 16
5 +22 +10	9 +38 +23	4 - 5 - 8
6 +22 +10	9 +38 +23	6 - 10 - 12 - 16
6 +22 +10	10 +38 +23	6 - 10 - 12 - 16
6 +22 +10	12 +46 +28	6 - 10 - 12 - 16
7 +23 +13	10 +38 +23	5 - 8 - 10
8 +23 +13	11 +46 +28	8 - 12 - 16 - 20
8 +23 +13	12 +46 +28	8 - 12 - 16 - 20
8 +23 +13	14 +46 +28	8 - 12 - 16 - 20
9 +23 +13	12 +46 +28	6 - 10 - 14
10 +23 +13	13 +46 +28	10 - 16 - 20 - 25
10 +23 +13	14 +46 +28	10 - 16 - 20 - 25
10 +23 +13	15 +46 +28	10 - 16 - 20 - 25
10 +23 +13	16 +46 +28	10 - 16 - 20 - 25
12 +34 +16	15 +46 +28	12 - 16 - 20 - 25
12 +34 +16	16 +46 +28	12 - 16 - 20 - 25
12 +34 +16	17 +46 +28	12 - 16 - 20 - 25
12 +34 +16	18 +46 +28	12 - 16 - 20 - 25
14 +34 +16	18 +46 +28	14 - 18 - 22 - 28

INSIDE Ø $D_i$	OUTSIDE Ø $D_o$	LENGTH B
14 +56 +35	20 +56 +35	14 - 18 - 22 - 28
15 +56 +35	19 +56 +35	16 - 20 - 25 - 32
15 +56 +35	21 +56 +35	16 - 20 - 25 - 32
16 +56 +35	20 +56 +35	16 - 20 - 25 - 32
16 +56 +35	22 +56 +35	16 - 20 - 25 - 32
18 +56 +35	22 +56 +35	18 - 22 - 28 - 36
18 +56 +35	24 +56 +35	18 - 22 - 28 - 36
18 +56 +35	25 +56 +35	18 - 22 - 28 - 36
20 +56 +35	24 +56 +35	16 - 20 - 25 - 32
20 +56 +35	25 +56 +35	16 - 20 - 25 - 32
20 +56 +35	26 +56 +35	16 - 20 - 25 - 32
20 +41 +20	27 +56 +35	16 - 20 - 25 - 32
20 +41 +20	28 +56 +35	16 - 20 - 25 - 32
22 +41 +20	27 +56 +35	18 - 22 - 28 - 36
22 +41 +20	28 +56 +35	18 - 22 - 28 - 36
22 +41 +20	29 +56 +35	18 - 22 - 28 - 36
25 +41 +20	30 +56 +35	20 - 25 - 32 - 40
25 +41 +20	32 +68 +43	20 - 25 - 32 - 40
28 +41 +20	32 +68 +43	22 - 28 - 36 - 45
28 +41 +20	33 +68 +43	22 - 28 - 36 - 45
28 +41 +20	36 +68 +43	22 - 28 - 36 - 45
30 +41 +20	38 +68 +43	24 - 30 - 38
32 +50 +25	38 +68 +43	20 - 25 - 33 - 40 - 50

INSIDE Ø $D_i$	OUTSIDE Ø $D_o$	LENGTH B
32 +50 +25	40 +68 +43	20 - 25 - 33 - 40 - 50
35 +50 +25	44 +68 +43	22 - 28 - 35
35 +50 +25	45 +68 +43	25 - 35 - 40 - 50
36 +50 +25	42 +68 +43	22 - 28 - 36 - 45
36 +50 +25	45 +68 +43	22 - 28 - 36 - 45
38 +50 +25	44 +68 +43	25 - 35 - 45
40 +50 +25	46 +68 +43	25 - 32 - 40 - 50
40 +50 +25	50 +68 +43	25 - 32 - 40 - 50
45 +50 +25	51 +99 +53	28 - 36 - 45 - 56
45 +50 +25	55 +99 +53	35 - 45 - 55 - 65
45 +50 +25	56 +99 +53	28 - 36 - 45 - 56
50 +50 +25	56 +99 +53	32 - 40 - 50 - 63
50 +50 +25	60 +99 +53	32 - 40 - 50 - 63
55 +76 +30	65 +99 +53	40 - 55 - 70
60 +76 +30	70 +105 +59	50 - 60 - 90 - 120
60 +76 +30	72 +105 +59	50 - 60 - 70
60 +76 +30	80 +105 +59	90 - 120
63 +76 +30	70 +105 +59	40 - 50
70 +76 +30	80 +105 +59	90 - 120
80 +90 +36	100 +125 +71	120
100 +90 +36	120 +133 +79	120
110 +90 +36	125 +155 +92	120
125 +106 +43	150 +163 +100	120

All tolerances in  $\mu\text{m}$

Cylindrical bushes with H7 (H8 for  $\varnothing \geq 50 \text{ mm}$ ) and flanged bushes with H8 inner diameter tolerance after being pressed into a housing with an inner diameter with H7 tolerance using a mandrel with m6 outer diameter tolerance. Delivery tolerance in accordance with ISO standard F7/s7 for cylindrical bushes (for  $D_i > 50 \text{ mm}$  and  $D_o > 50 \text{ mm}$  F8/s8) and F8/s8 for flanged bushes.

## 8.2 IRON BASED GGB-FP20 CYLINDRICAL BEARINGS

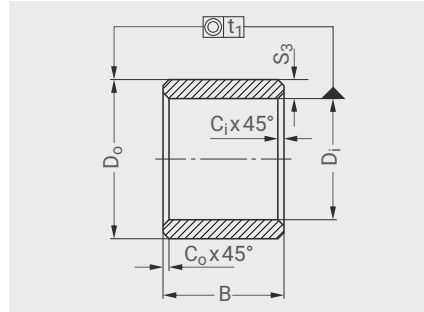

$t_1$  for  $D_i \leq 20 \text{ mm} = 50 \mu\text{m}$   
 $t_1$  for  $20 \text{ mm} < D_i \leq 35 \text{ mm} = 70 \mu\text{m}$   
 $t_1$  for  $D_i > 35 = 100 \mu\text{m}$   
 chamfers  $C = (0.1 \text{ to } 0.2) S_3$   
 minimum 0.2 mm

$B > 10 \pm 1\%$   
 $B \leq 10 \pm 0.1 \text{ mm}$

INSIDE Ø $D_i$	OUTSIDE Ø $D_o$	LENGTH B
3 +16 +6	6 +31 +19	4 - 10
4 +22 +10	8 +38 +23	8
6 +22 +10	9 +38 +23	6 - 10 - 12 - 16
6 +22 +10	10 +38 +23	6 - 10 - 16
6 +22 +10	12 +46 +28	6
8 +23 +13	11 +46 +28	8 - 12 - 16
8 +23 +13	12 +46 +28	8 - 12 - 16 - 20
10 +23 +13	13 +46 +28	10 - 20 - 25
10 +23 +13	14 +46 +28	10 - 16 - 20
10 +23 +13	15 +46 +28	10
12 +34 +16	15 +46 +28	12 - 16 - 20
12 +34 +16	16 +46 +28	12 - 16 - 20 - 25
12 +34 +16	17 +46 +28	12
14 +34 +16	18 +46 +28	14 - 18 - 22

INSIDE Ø $D_i$	OUTSIDE Ø $D_o$	LENGTH B
14 +34 +16	20 +56 +35	14 - 28
15 +34 +16	19 +56 +35	16 - 20
16 +34 +16	20 +56 +35	16 - 20 - 25 - 32
16 +34 +16	22 +56 +35	16 - 20 - 25
18 +34 +16	22 +56 +35	18 - 22
18 +34 +16	24 +56 +35	22
20 +41 +20	24 +56 +35	16 - 20 - 25 - 32
20 +41 +20	26 +56 +35	16 - 20 - 25 - 32
22 +41 +20	27 +56 +35	18 - 22
25 +41 +20	30 +56 +35	20 - 25 - 32
25 +41 +20	32 +68 +43	20 - 25 - 32
30 +41 +20	38 +68 +43	24 - 30 - 38
32 +50 +25	38 +68 +43	32
35 +50 +25	44 +68 +43	22 - 28 - 35

INSIDE Ø $D_i$	OUTSIDE Ø $D_o$	LENGTH B
36 +50 +25	42 +68 +43	22
40 +50 +25	46 +68 +43	25 - 32 - 40
40 +50 +25	50 +68 +43	25 - 32 - 40 - 50
45 +50 +25	51 +99 +53	28 - 45
45 +50 +25	55 +99 +53	35
45 +50 +25	56 +99 +53	36
50 +50 +25	56 +99 +53	32
50 +50 +25	60 +99 +53	30 - 50
60 +76 +30	70 +105 +59	60 - 90
70 +76 +30	80 +105 +59	120
80 +90 +36	100 +125 +71	120
100 +90 +36	120 +133 +79	120

All tolerances in  $\mu\text{m}$

Cylindrical bushes with H7 (H8 for  $\varnothing \geq 50 \text{ mm}$ ) and flanged bushes with H8 inner diameter tolerance after being pressed into a housing with an inner diameter with H7 tolerance using a mandrel with m6 outer diameter tolerance.  
 Delivery tolerance in accordance with ISO standard F7/s7 for cylindrical bushes (for  $D_i > 50 \text{ mm}$  and  $D_o > 50 \text{ mm}$  F8/s8) and F8/s8 for flanged bushes.

## 8.3 BRONZE BASED GGB-BP25 FLANGED BEARINGS

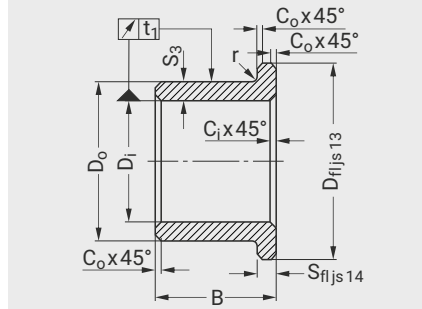

$t_1$  for  $D_i \leq 20 \text{ mm} = 60 \mu\text{m}$   
 $t_1$  for  $20 \text{ mm} < D_i \leq 35 \text{ mm} = 80 \mu\text{m}$   
 $t_1$  for  $D_i > 35 = 100 \mu\text{m}$   
 chamfers  $C = (0.1 \text{ to } 0.2) S_3$   
 minimum  $0.2 \text{ mm}$   
 $r = \text{max. } 0.3 \times S_3$   
 $B > 10 \pm 1\%$   
 $B \leq 10 \pm 0.1 \text{ mm}$

INSIDE Ø $D_i$	OUTSIDE Ø $D_o$	FLANGE Ø $D_{fl}$	FLANGE THICKNESS $S_{fl}$	LENGTH B		
3	+20 +6	6	+37 +19	9	1.5	4 - 6 - 10
4	+28 +10	8	+45 +23	12	2	4 - 8 - 12
6	+28 +10	10	+45 +23	14	2	6 - 10 - 16
8	+35 +13	12	+55 +28	16	2	8 - 12 - 16
9	+35 +13	14	+55 +28	19	2.5	6 - 10 - 14
10	+35 +13	13	+55 +28	16	1.5	10 - 16 - 20
10	+35 +13	15	+55 +28	20	2.5	10 - 16 - 20
10	+35 +13	16	+55 +28	22	3	9 - 10 - 16
12	+43 +16	15	+55 +28	18	1.5	12 - 16 - 20
12	+43 +16	17	+55 +28	22	2.5	12 - 16 - 20 - 25
12	+43 +16	18	+55 +28	24	3	8 - 12 - 20
14	+43 +16	18	+55 +28	22	2	14 - 18 - 22
14	+43 +16	20	+68 +35	26	3	14 - 18 - 22 - 28
15	+43 +16	19	+68 +35	23	2	16 - 20 - 25
15	+43 +16	21	+68 +35	27	3	16 - 20 - 25 - 32
16	+43 +16	20	+68 +35	24	2	16 - 20 - 25
16	+43 +16	22	+68 +35	28	3	16 - 20 - 25 - 32
18	+43 +16	22	+68 +35	26	2	18 - 22 - 28
18	+43 +16	24	+68 +35	30	3	18 - 22 - 28
20	+53 +20	24	+68 +35	28	2	16 - 20 - 25

INSIDE Ø $D_i$	OUTSIDE Ø $D_o$	FLANGE Ø $D_{fl}$	FLANGE THICKNESS $S_{fl}$	LENGTH B		
20	+53 +20	26	+68 +35	32	3	16 - 20 - 25 - 32
22	+53 +20	27	+68 +35	32	2.5	18 - 22 - 28
22	+53 +20	28	+68 +35	34	3	15 - 20 - 25 - 30
22	+53 +20	29	+68 +35	36	3.5	18 - 22 - 28 - 36
25	+53 +20	30	+68 +35	35	2.5	20 - 25 - 32
25	+53 +20	32	+82 +43	39	3.5	20 - 25 - 32
28	+53 +20	33	+82 +43	38	2.5	22 - 28 - 36
28	+53 +20	36	+82 +43	44	4	22 - 28 - 36
30	+53 +20	38	+82 +43	46	4	20 - 25 - 30
32	+64 +25	38	+82 +43	44	3	20 - 25 - 32
32	+64 +25	40	+82 +43	48	4	20 - 25 - 30 - 32
36	+64 +25	42	+82 +43	48	3	22 - 28 - 36
36	+64 +25	45	+82 +43	54	4.5	22 - 28 - 36
40	+64 +25	46	+82 +43	52	3	25 - 32 - 40
40	+64 +25	50	+82 +43	60	5	25 - 32 - 40
45	+64 +25	51	+99 +53	57	3	28 - 36 - 45
45	+64 +25	56	+99 +53	67	5.5	28 - 36 - 45
50	+64 +25	56	+99 +53	62	3	32 - 40 - 50
50	+64 +25	60	+99 +53	70	5	32 - 40 - 50
60	+64 +25	70	+105 +59	80	5	50 - 60

All tolerances in  $\mu\text{m}$

Cylindrical bushes with H7 (H8 for  $\varnothing \geq 50 \text{ mm}$ ) and flanged bushes with H8 inner diameter tolerance after being pressed into a housing with an inner diameter with H7 tolerance using a mandrel with m6 outer diameter tolerance.

Delivery tolerance in accordance with ISO standard F7/s7 for cylindrical bushes (for  $D_i > 50 \text{ mm}$  and  $D_o > 50 \text{ mm}$  F8/s8) and F8/s8 for flanged bushes.

## 8.4 IRON BASED GGB-BFP20 FLANGED BEARINGS

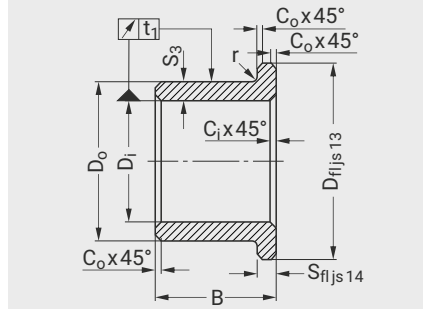

$t_1$  for  $D_i \leq 20 \text{ mm} = 60 \mu\text{m}$   
 $t_1$  for  $20 \text{ mm} < D_i \leq 35 \text{ mm} = 80 \mu\text{m}$   
 $t_1$  for  $D_i > 35 = 100 \mu\text{m}$   
 chamfers  $C = (0.1 \text{ to } 0.2) S_3$   
 minimum  $0.2 \text{ mm}$   
 $r = \text{max. } 0.3 \times S_3$   
 $B > 10 \pm 1\%$   
 $B \leq 10 \pm 0.1 \text{ mm}$

INSIDE Ø $D_i$	OUTSIDE Ø $D_o$	FLANGE Ø $D_{fl}$	FLANGE THICKNESS $S_{fl}$	LENGTH B
3 $\begin{smallmatrix} +20 \\ +6 \end{smallmatrix}$	6 $\begin{smallmatrix} +28 \\ +10 \end{smallmatrix}$	9	1.5	4
6 $\begin{smallmatrix} +28 \\ +10 \end{smallmatrix}$	10 $\begin{smallmatrix} +45 \\ +23 \end{smallmatrix}$	14	2	6 - 10 - 16
8 $\begin{smallmatrix} +35 \\ +13 \end{smallmatrix}$	12 $\begin{smallmatrix} +55 \\ +28 \end{smallmatrix}$	16	2	8 - 12 - 16
10 $\begin{smallmatrix} +35 \\ +13 \end{smallmatrix}$	13 $\begin{smallmatrix} +55 \\ +28 \end{smallmatrix}$	16	1.5	10 - 16
10 $\begin{smallmatrix} +35 \\ +13 \end{smallmatrix}$	15 $\begin{smallmatrix} +55 \\ +28 \end{smallmatrix}$	20	2.5	10 - 16 - 20
12 $\begin{smallmatrix} +43 \\ +16 \end{smallmatrix}$	15 $\begin{smallmatrix} +55 \\ +28 \end{smallmatrix}$	18	1.5	12 - 16 - 20
12 $\begin{smallmatrix} +43 \\ +16 \end{smallmatrix}$	17 $\begin{smallmatrix} +55 \\ +28 \end{smallmatrix}$	22	2.5	12 - 16
14 $\begin{smallmatrix} +43 \\ +16 \end{smallmatrix}$	18 $\begin{smallmatrix} +55 \\ +28 \end{smallmatrix}$	22	2	14 - 18 - 22
16 $\begin{smallmatrix} +43 \\ +16 \end{smallmatrix}$	20 $\begin{smallmatrix} +68 \\ +35 \end{smallmatrix}$	24	2	16 - 20
16 $\begin{smallmatrix} +43 \\ +16 \end{smallmatrix}$	22 $\begin{smallmatrix} +68 \\ +35 \end{smallmatrix}$	28	3	16 - 20 - 25
18 $\begin{smallmatrix} +43 \\ +16 \end{smallmatrix}$	24 $\begin{smallmatrix} +68 \\ +35 \end{smallmatrix}$	30	3	18 - 22

INSIDE Ø $D_i$	OUTSIDE Ø $D_o$	FLANGE Ø $D_{fl}$	FLANGE THICKNESS $S_{fl}$	LENGTH B
20 $\begin{smallmatrix} +53 \\ +20 \end{smallmatrix}$	24 $\begin{smallmatrix} +68 \\ +35 \end{smallmatrix}$	28	2	16 - 20 - 25
20 $\begin{smallmatrix} +53 \\ +20 \end{smallmatrix}$	26 $\begin{smallmatrix} +68 \\ +35 \end{smallmatrix}$	32	3	16 - 20 - 25
22 $\begin{smallmatrix} +53 \\ +20 \end{smallmatrix}$	29 $\begin{smallmatrix} +68 \\ +35 \end{smallmatrix}$	36	3.5	18 - 22 - 28 - 36
25 $\begin{smallmatrix} +53 \\ +20 \end{smallmatrix}$	30 $\begin{smallmatrix} +68 \\ +35 \end{smallmatrix}$	35	2.5	20 - 32
25 $\begin{smallmatrix} +53 \\ +20 \end{smallmatrix}$	32 $\begin{smallmatrix} +82 \\ +43 \end{smallmatrix}$	39	3.5	25 - 32
30 $\begin{smallmatrix} +53 \\ +20 \end{smallmatrix}$	38 $\begin{smallmatrix} +82 \\ +43 \end{smallmatrix}$	46	4	30
32 $\begin{smallmatrix} +64 \\ +25 \end{smallmatrix}$	40 $\begin{smallmatrix} +82 \\ +43 \end{smallmatrix}$	48	4	20 - 32
36 $\begin{smallmatrix} +64 \\ +25 \end{smallmatrix}$	45 $\begin{smallmatrix} +82 \\ +43 \end{smallmatrix}$	51	4.5	22 - 36
40 $\begin{smallmatrix} +64 \\ +25 \end{smallmatrix}$	50 $\begin{smallmatrix} +82 \\ +43 \end{smallmatrix}$	60	5	25 - 32 - 40
50 $\begin{smallmatrix} +64 \\ +25 \end{smallmatrix}$	60 $\begin{smallmatrix} +99 \\ +53 \end{smallmatrix}$	70	5	50
60 $\begin{smallmatrix} +76 \\ +30 \end{smallmatrix}$	70 $\begin{smallmatrix} +105 \\ +59 \end{smallmatrix}$	80	5	50 - 60

All tolerances in  $\mu\text{m}$

Cylindrical bushes with H7 (H8 for  $\varnothing \geq 50 \text{ mm}$ ) and flanged bushes with H8 inner diameter tolerance after being pressed into a housing with an inner diameter with H7 tolerance using a mandrel with m6 outer diameter tolerance. Delivery tolerance in accordance with ISO standard F7/s7 for cylindrical bushes (for  $D_i > 50 \text{ mm}$  and  $D_o > 50 \text{ mm}$  F8/s8) and F8/s8 for flanged bushes.

## 8.5 CYLINDRICAL BLANKS

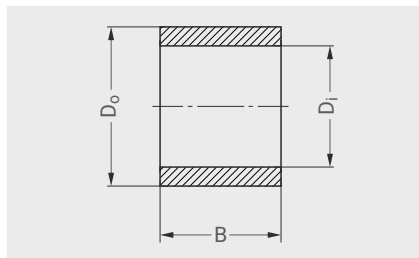

INSIDE Ø $D_i$	GGB-BP25 OUTSIDE Ø $D_o$	LENGTH B
38 $\begin{smallmatrix} +0.8 \\ -0.8 \end{smallmatrix}$	70 $\begin{smallmatrix} +1.5 \\ -1.5 \end{smallmatrix}$	120 $\begin{smallmatrix} +4.0 \\ -0.0 \end{smallmatrix}$
45 $\begin{smallmatrix} +0.8 \\ -0.8 \end{smallmatrix}$	105 $\begin{smallmatrix} +1.5 \\ -1.5 \end{smallmatrix}$	120 $\begin{smallmatrix} +4.0 \\ -0.0 \end{smallmatrix}$
80 $\begin{smallmatrix} +0.8 \\ -0.8 \end{smallmatrix}$	145 $\begin{smallmatrix} +2.0 \\ -2.0 \end{smallmatrix}$	120 $\begin{smallmatrix} +4.0 \\ -0.0 \end{smallmatrix}$
80 $\begin{smallmatrix} +0.8 \\ -0.8 \end{smallmatrix}$	175 $\begin{smallmatrix} +2.0 \\ -2.0 \end{smallmatrix}$	120 $\begin{smallmatrix} +4.0 \\ -0.0 \end{smallmatrix}$
85 $\begin{smallmatrix} +1.5 \\ -1.5 \end{smallmatrix}$	105 $\begin{smallmatrix} +2.0 \\ -2.0 \end{smallmatrix}$	120 $\begin{smallmatrix} +4.0 \\ -0.0 \end{smallmatrix}$

INSIDE Ø $D_i$	GGB-FP20 OUTSIDE Ø $D_o$	LENGTH B
38 $\begin{smallmatrix} +0.8 \\ -0.8 \end{smallmatrix}$	70 $\begin{smallmatrix} +1.5 \\ -1.5 \end{smallmatrix}$	120 $\begin{smallmatrix} +4.0 \\ -0.0 \end{smallmatrix}$
45 $\begin{smallmatrix} +0.8 \\ -0.8 \end{smallmatrix}$	105 $\begin{smallmatrix} +1.5 \\ -1.5 \end{smallmatrix}$	120 $\begin{smallmatrix} +4.0 \\ -0.0 \end{smallmatrix}$
80 $\begin{smallmatrix} +0.8 \\ -0.8 \end{smallmatrix}$	145 $\begin{smallmatrix} +2.0 \\ -2.0 \end{smallmatrix}$	120 $\begin{smallmatrix} +4.0 \\ -0.0 \end{smallmatrix}$
80 $\begin{smallmatrix} +0.8 \\ -0.8 \end{smallmatrix}$	175 $\begin{smallmatrix} +2.0 \\ -2.0 \end{smallmatrix}$	120 $\begin{smallmatrix} +4.0 \\ -0.0 \end{smallmatrix}$
85 $\begin{smallmatrix} +1.5 \\ -1.5 \end{smallmatrix}$	105 $\begin{smallmatrix} +2.0 \\ -2.0 \end{smallmatrix}$	120 $\begin{smallmatrix} +4.0 \\ -0.0 \end{smallmatrix}$

INSIDE Ø $D_i$	GGB-S016 OUTSIDE Ø $D_o$	LENGTH B
38 $\begin{smallmatrix} +0.8 \\ -0.8 \end{smallmatrix}$	70 $\begin{smallmatrix} +1.5 \\ -1.5 \end{smallmatrix}$	120 $\begin{smallmatrix} +4.0 \\ -0.0 \end{smallmatrix}$
45 $\begin{smallmatrix} +0.8 \\ -0.8 \end{smallmatrix}$	105 $\begin{smallmatrix} +1.5 \\ -1.5 \end{smallmatrix}$	120 $\begin{smallmatrix} +4.0 \\ -0.0 \end{smallmatrix}$
80 $\begin{smallmatrix} +0.8 \\ -0.8 \end{smallmatrix}$	145 $\begin{smallmatrix} +2.0 \\ -2.0 \end{smallmatrix}$	120 $\begin{smallmatrix} +4.0 \\ -0.0 \end{smallmatrix}$
80 $\begin{smallmatrix} +0.8 \\ -0.8 \end{smallmatrix}$	175 $\begin{smallmatrix} +2.0 \\ -2.0 \end{smallmatrix}$	120 $\begin{smallmatrix} +4.0 \\ -0.0 \end{smallmatrix}$
85 $\begin{smallmatrix} +1.5 \\ -1.5 \end{smallmatrix}$	105 $\begin{smallmatrix} +2.0 \\ -2.0 \end{smallmatrix}$	120 $\begin{smallmatrix} +4.0 \\ -0.0 \end{smallmatrix}$

All tolerances in  $\mu\text{m}$

## 8.6 SOLID ROD BLANKS

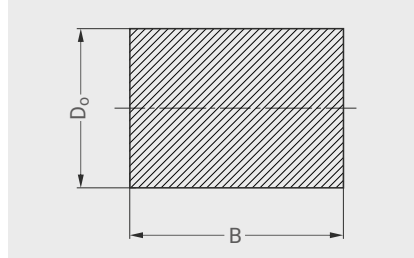

GGB-BP25		LENGTH B	
OUTSIDE Ø D <sub>o</sub>			
20	+0.8 -0.8	40	+4.0 +0.0
30	+0.8 -0.8	50	+4.0 +0.0
45	+0.8 -0.8	90	+4.0 +0.0
54	+0.8 -0.8	110	+4.0 +0.0
70	+0.8 -0.8	120	+4.0 +0.0
105	+0.8 -0.8	120	+4.0 +0.0
145	+1.5 -1.5	120	+4.0 +0.0

GGB-FP20		LENGTH B	
OUTSIDE Ø D <sub>o</sub>			
20	+0.8 -0.8	40	+4.0 +0.0
30	+0.8 -0.8	50	+4.0 +0.0
45	+0.8 -0.8	90	+4.0 +0.0
54	+0.8 -0.8	110	+4.0 +0.0
70	+0.8 -0.8	120	+4.0 +0.0
105	+0.8 -0.8	120	+4.0 +0.0
145	+1.5 -1.5	120	+4.0 +0.0

GGB-S016		LENGTH B	
OUTSIDE Ø D <sub>o</sub>			
20	+0.8 -0.8	40	+4.0 +0.0
30	+0.8 -0.8	50	+4.0 +0.0
45	+0.8 -0.8	90	+4.0 +0.0
54	+0.8 -0.8	110	+4.0 +0.0
70	+0.8 -0.8	120	+4.0 +0.0
105	+0.8 -0.8	120	+4.0 +0.0
145	+1.5 -1.5	120	+4.0 +0.0

All tolerances in mm

## 8.7 SPHERICAL BEARINGS

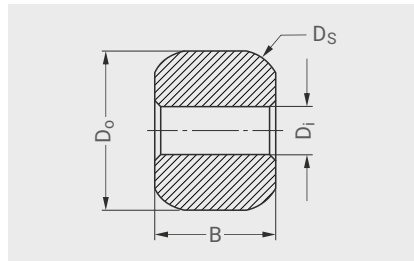

INSIDE Ø D <sub>i</sub>	GGB-BP25 / GGB-FP20		LENGTH B				
	SPHERICAL Ø D <sub>s</sub>	OUTSIDE Ø D <sub>o</sub>					
4	+0.012 +0.0	10	+0.05 -0.05	9.5	+0.2 -0.2	8	+0.1 -0.1
5	+0.012 +0.0	13	+0.05 -0.05	12.5	+0.2 -0.2	10	+0.1 -0.1
6	+0.012 +0.0	13	+0.05 -0.05	12.6	+0.2 -0.2	8	+0.1 -0.1
6	+0.012 -0.0	15	+0.05 -0.05	14.5	+0.2 -0.2	12	+0.1 -0.1
6	+0.012 +0.0	16	+0.05 -0.05	15.5	+0.2 -0.2	12.5	+0.1 -0.1
7	+0.012 +0.0	17	+0.05 -0.05	16.5	+0.2 -0.2	14	+0.1 -0.1
8	+0.012 +0.0	16	+0.05 -0.05	15.5	+0.2 -0.2	12.5	+0.1 -0.1

All tolerances in mm

# Bearing Application Data Sheet

Not sure which GGB part fits your application requirements?

Please complete the form below and share it with your GGB sales person or distributor representative.

## DATA FOR BEARING DESIGN CALCULATION

New Design  Existing Design

Application: \_\_\_\_\_

Project/No.: \_\_\_\_\_ Quantity: \_\_\_\_\_

DIMENSIONS [mm]	
Inside diameter	$D_i$
Outside diameter	$D_o$
Length	$B$
Outer ring length	$B_F$
Flange Diameter	$D_{fi}$
Flange thickness	$B_{fi}$
Wall thickness	$S_T$
Length of slideplate	$L$
Width of slideplate	$W$
Thickness of slideplate	$S_s$

LOAD	
<input type="checkbox"/> Static load	
<input type="checkbox"/> Dynamic load	
Axial load $F$	[N]
Radial load $F$	[N]

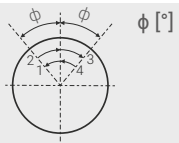
MOVEMENT	
Rotational speed	$N$ [1/min]
Speed	$U$ [m/s]
Length of stroke	$L_s$ [mm]
Frequency of stroke	[1/min]
Oscillating cycle	$\phi$ [°]
	
Osc. frequency	$N_{osz}$ [1/min]

MATING SURFACE	
Material	
Hardness	HB/HRC
Surface finish	$R_a$ [µm]

## CUSTOMER INFORMATION

Company \_\_\_\_\_

Street \_\_\_\_\_

City / State / Province / Post Code \_\_\_\_\_

Telephone \_\_\_\_\_ Fax \_\_\_\_\_

Name \_\_\_\_\_

Email Address \_\_\_\_\_ Date \_\_\_\_\_

FITS & TOLERANCES	
Shaft	$D_J$
Bearing housing	$D_H$

OPERATING ENVIRONMENT	
Ambient temperature	$T_{amb}$ [°]
Bearing housing material	

- Housing with good heating transfer properties
- Light pressing or insulated housing with poor heat transfer properties
- Non metal housing with poor heat transfer properties
- Alternate operation in water and dry

LUBRICATION	
<input type="checkbox"/> Dry	
<input type="checkbox"/> Continuous lubrication	
<input type="checkbox"/> Process fluid lubrication	
<input type="checkbox"/> Initial lubrication only	
<input type="checkbox"/> Hydrodynamic conditions	
Process fluid	
Lubricant	
Dynamic viscosity	$\eta$ [mPas]

SERVICE HOURS PER DAY	
Continuous operation	
Intermittent operation	
Operating time	
Days per year	

SERVICE LIFE	
Required service life	$L_H$ [h]

## BEARING TYPE

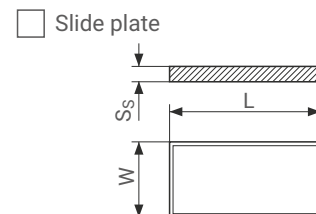
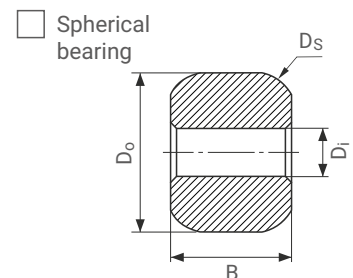
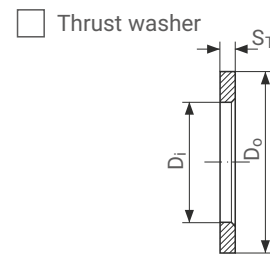
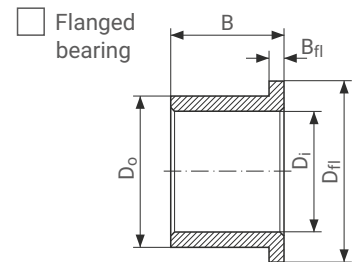
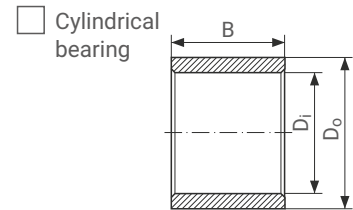

- Special parts (sketch)
- Steady load
- Rotating load
- Rotational movement
- Oscillating movement
- Linear movement

# Product Information

---

GGB assures the products described in this document have no manufacturing errors or material deficiencies.

The details set out in this document are registered to assist in assessing material suitability for intended use. They have been developed from our own investigations as well as generally accessible publications. They do not represent any assurance for the properties themselves.

Unless expressly declared in writing, GGB gives no warranty that the products described are suited for any particular purpose or specific operating circumstances. GGB accepts no liability for any losses, damages, or costs however they may arise through direct or indirect use of these products.

GGB's sales and delivery terms and conditions, included as an integral part of quotations, stock and price lists, apply absolutely to all business conducted by GGB. Copies can be made available on request.

Products are subject to continual development. GGB retains the right to make specification amendments or improvements to technical data without prior announcement. Edition 2023 (this edition replaces earlier editions which hereby lose their validity).

## **STATEMENT REGARDING LEAD CONTENT IN GGB PRODUCTS & EU DIRECTIVE COMPLIANCE**

GGB is committed to adhering to all U.S., European, and international standards and regulations with regard to lead content. We have established internal processes that monitor any changes to existing standards and regulations, and we work collaboratively with customers and distributors to ensure all requirements are strictly followed. This includes RoHS and REACH guidelines.

GGB makes it a top priority to operate in an environmentally conscious and safe manner. We follow numerous industry best practices and are committed to meeting or exceeding a variety of internationally recognized standards for emissions control and workplace safety.

Each of our global locations has management systems in place that adhere to IATF 16949, ISO 9001, ISO 14001, ISO 45001, and AS9100D/EN9100 quality regulations.

All of our certificates can be found here: <https://www.ggbearings.com/en/certificates>. A detailed explanation of our commitment to REACH and RoHS directives can be found at:

<https://www.ggbearings.com/en/who-we-are/quality-and-environment>.

©2023 GGB. All rights reserved.

# PUSHING BOUNDARIES TO CO-CREATE A HIGHER QUALITY OF LIFE



Standard- und Sondergleitlager beziehen über  
[www.caspar-gleitlager.de](http://www.caspar-gleitlager.de)



IN119ENG03-23USA