



GGB UNI/MINI/EXALIGN™

**SELF-ALIGNING BEARING HOUSINGS FOR
SELF-LUBRICATED AND LUBRICATED APPLICATIONS**

GGB began in 1899 as Glacier Antifriction Metal Company, producing plain bearings and introducing many successful new products to the market, including internationally recognized polymer materials. Over the past 120 years, our company has continued forming strategic partnerships, continuously expanding into a global network of manufacturing facilities, increasing production capabilities and resources to become who we are today: world leaders in tribological innovation.

Today, our products can be found everywhere – from scientific vessels at the bottom of the ocean to racecars speeding down the tarmac to jumbo jets slicing through the sky to the Curiosity rover exploring the surface of Mars.

Throughout our history, safety, excellence and respect have formed the foundational values for the entire GGB family. They are of paramount importance as we seek to maximize personal possibility, achieve excellence and establish open, creative work environments with the highest safety standards in the industry.



SAFETY

GGB's deep-rooted culture of safety places a relentless focus on creating a secure, healthy work environment for all. A core value of GGB, safety is critical at all levels of business in order to achieve our goal of having the safest employees in the industry.



EXCELLENCE

A world-class organization is built by fostering excellence throughout the company, across all roles. Our world-class manufacturing plants are certified in quality and excellence in the industry according to ISO 9001, IATF 16949, ISO 14001 and ISO 45001, allowing us to access the industry's best practices while aligning our quality management system with global standards.

For a complete listing of our certifications, please visit our website:

<https://www.ggbearings.com/en/certificates>



RESPECT

Our teams work together with mutual respect regardless of background, nationality, or function, embracing the diversity of people and learning from one another - after all, with respect comes both individual and group growth.

Table of Contents

1 Introduction	4	3 Dimensions	8
1.1 Self-aligning Bearing Housings	4	3.1 UNI Bearing Housings	8
1.2 Characteristics and Advantages	5	3.2 MINI Bearing Housings	10
1.3 Standard Housings	5	3.3 EXALIGN™ PB Bearing Housings	10
2 Loading Data	6	3.4 EXALIGN™ DF Bearing Housings	12
2.1 Radial Loads	6	3.5 EXALIGN™ FL Bearing Housings	12
2.2 Axial Loads	7	4 Lubrication	14
		5 Applications	17
		6 Bearing Application Data Sheet	21
		7 Product Information	22

The GGB Advantage



LOWER SYSTEM COST

GGB bearings reduce shaft costs by eliminating the need for hardening and machining grease paths. Their compact, one-piece construction provides space and weight savings and simplifies assembly.



LOW-FRICTION, HIGH WEAR RESISTANCE

Low coefficients of friction eliminate the need for lubrication, while providing smooth operation, reducing wear and extending service life. Low-friction also eliminates the effects of stick-slip or “stiction” during start up.



MAINTENANCE-FREE

GGB bearings are self-lubricating, making them ideal for applications requiring long bearing life without continuous maintenance, as well as operating conditions with inadequate or no lubrication.



ENVIRONMENTAL

Greaseless, lead-free GGB bearings comply with increasingly stringent environmental regulations such as the EU RoHS directive restricting the use of hazardous substances in certain types of electrical and electronic equipment.



CUSTOMER SUPPORT

GGB’s flexible production platform and extensive supply network assure quick turnaround and timely deliveries. In addition, we offer local applications engineering and technical support.



GLOBAL FOOTPRINT

Our global presence and local logistics networks ensure our customers receive only the highest quality bearing solutions, in a timely manner and with extensive engineering support.

We don't just make products, we build partnerships. That's the GGB Advantage.

1 Introduction

The continuous improvements made in today's machinery and equipment are heavily dependent on the performance of the bearings.

The bearings are expected to perform under increasingly difficult operating conditions and still offer greater reliability, a longer service life with reduced maintenance and a lower cost of ownership.

GGB brings more than 120 years of experience and accumulated expertise in self-lubricating bearings, offering an extensive portfolio of bearing products and technical application knowledge across a wide range of industries. Our application engineering team can provide assistance in:

- Selection of the optimal type of bearing for your application
- Design with either standard or custom products
- Calculation of estimated life expectancy
- Assembly and installation

GGB offers the most advanced bearing products in the industry, supported by laboratory testing in state-of-the-art facilities, produced according to the highest quality standards.

1.1 SELF-ALIGNING BEARING HOUSINGS

The self-aligning bearing housings are available in standard ranges:

- EXALIGN™ PB plummer blocks and EXALIGN™ DF and FL flanged bearing housings
- MINI and UNI bearing housings that can be mounted as either plummer blocks or flanged bearing housings.

The brochure gives information on the various types of housings, their construction, dimensions, load capacity and the different options of assemblies incorporating maintenance-free and low maintenance plain bearings.

1.2 CHARACTERISTICS AND ADVANTAGES

- Self-aligning bearing housings enable simple compensation of system misalignment
- Misalignment up to $\pm 5^\circ$ permitted
- All-purpose EXALIGN™ flanged DF and FL bearing housings and EXALIGN™ PB pedestal bearing housings are suitable for high loads
- Choice of various housings, spherical inserts and bearings to suit all configurations and operating conditions
- Mounting of GGB bearings for optimal bearing solutions
- Spherical insert is secured against distortion

1.3 STANDARD HOUSINGS



UNI Housing



MINI Housing

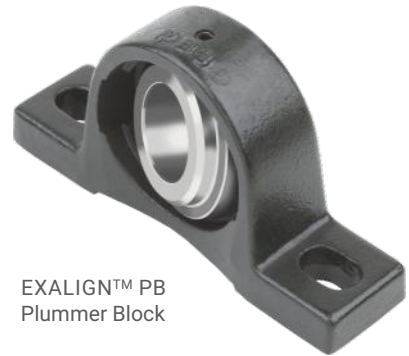

EXALIGN™ PB
Plummer Block



EXALIGN™ DF
Flanged Housing



EXALIGN™ FL
Flanged Housing

HOUSING TYPE	BEARING $\varnothing D_i$	DESCRIPTION
MINI	8 - 15 mm	Plummer block or flanged housing
UNI	10 - 100 mm	Plummer block or flanged housing
EXALIGN Type PB	10 - 100 mm	Plummer block
EXALIGN Type DF	10 - 100 mm	Flanged Housing – 2 bolts
EXALIGN Type FL	10 - 100 mm	Flanged Housing – 4 bolts

HOUSING TYPE	HOUSING MATERIAL	SPHERICAL INSERT MATERIAL
MINI bearing housing	Aluminium (AlMgSi12)	Steel (9SMn28K)
UNI bearing housing	Ductile cast iron (GGG40)	Steel (16MnCr5)
EXALIGN	Cast iron (GG20)	Cast iron (GG20)

2 Loading Data

2.1 RADIAL LOADS

GGB plain bearing products such as DU® and DX® can be used in high load applications. The maximum permissible loading for the bearing, particularly at slow sliding speeds, may exceed the load limit of the bearing housing or the fixing bolts.

The following data for MINI, UNI and EXALIGN™ bearing housings were determined by laboratory testing. They are dependant on housing material and design shape.

The load limits for the MINI bearing housings were determined by the housing strength or the load limits of the 6 mm fixing bolts and depend on the direction of the load.

UNI bearing housings are stronger than the fixing bolts. The load limits given apply for 12.9 bolts (tensile strength 1 200 N/mm², 0.2% yield strength 1 080 N/mm², elongation at rupture 8%).

The data given for EXALIGN™ housings is based on the strength of grey cast iron that is used in the standard housings and suitable for most applications. Alternatively, higher strength materials are available on request. Please contact your local GGB sales representative.

UNI Technical Data

LOAD LIMIT VALUES FOR RADIAL FORCES				
Size	Bush ID	Max. Radial Load [N] (Housing)	Max. Radial Load [N] (Bolt)	Max. Shear Off Load [N] (Bolt)
1	10 - 25	20 000	10 000	1 000
2	28 - 40	30 000	15 000	1 500
3	45 - 60	50 000	25 000	2 500
4	65 - 80	90 000	45 000	4 500
5	85 - 100	125 000	62 500	6 000

The given data for UNI bearing housings are valid for 12.9 bolts (DIN EN 20898, part 1), as the housing load limit exceeds the load limit of the fixing bolts.

MINI Technical Data

LOAD LIMIT VALUES FOR RADIAL FORCES				
Size	Bush ID	Max. Radial Load [N] (Housing)	Max. Radial Load [N] (Bolt)	Max. Shear Off Load [N] (Bolt)
0	8 - 15	10 000	5 000	500

The load limit for MINI bearing housings is determined by the housing load limit or by the load limit of the of the fixing bolts (6mm diameter), depending on the load direction.

EXALIGN™ Technical Data

LOAD LIMIT VALUES FOR RADIAL FORCES		EXALIGN™ PB PLUMMER BLOCK	EXALIGN™ FL / DF 4-HOLES / 2-HOLES FLANGED HOUSING
Size	Bush ID	Max. Radial Load (N)	Max. Radial Load (N)
1	10 - 15	4 250	3 750
2	20 - 25	7 700	5 900
3	30	9 500	8 000
4	35 - 40	17 000	11 000
5	45	23 000	12 000
6	50	25 000	14 500
7	55 - 60	30 000	16 000
8	70 - 75	38 000	17 000
9	80 - 85	45 500	27 000
10	90 - 100	74 500	30 500

2.2 AXIAL LOADS

All of the housing assemblies are designed to accommodate low axial loads only, for example, those arising from location forces. Axial loads should be limited in each case to no more than 5% of the maximum radial loads quoted above. Under service conditions of continuous axial loading, it is advisable to use a stepped shaft operating against either a flanged bearing or a KA Glacetal thrust washer.

The estimated service life for the axial bearing should be calculated using the actual axial loads.

3 Dimensions

3.1 UNI SELF-ALIGNING BEARING HOUSINGS



UNI Bearing Housing

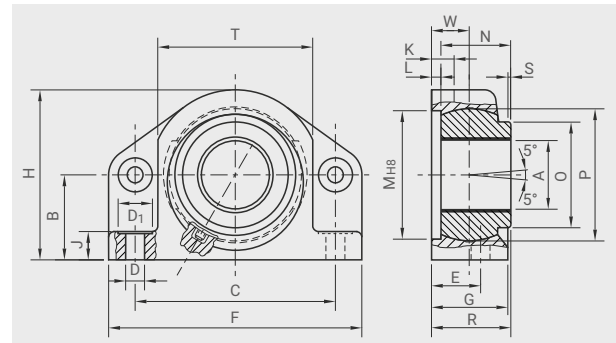
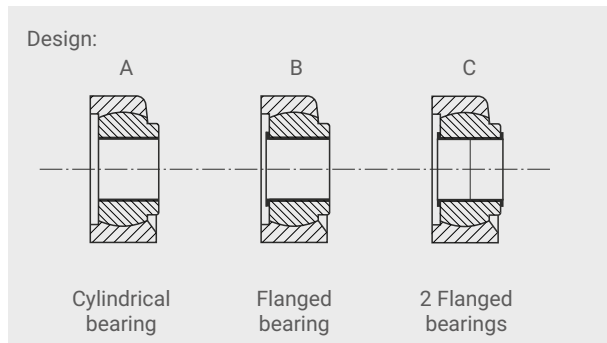

Housing material: GGG40

Spherical insert material: 16 MnCr5

Corrosion-resistant version on request.

Ordering example:

Size Design
UNI-1-10-B-DU — Bush product
 Standard bush D_i

DIMENSIONS [mm] UNI BEARING HOUSING

Size	Ø-range A*	B	C	D	D_1	E	F	G	H	J	K	L	M	N	O	P	R	S	T	W
1	10 - 25	28	72	8.5	13.5	17	95	25	56	12	8	3	46	20	34	42	23	0.5 x 45°	52	11
2	30 - 40	42	104	10.5	18	25	130	41	84	14	14	5	72	40	51	68	45	2 x 45°	83	20
3	45 - 60	60	142	13.5	27	35	180	55	120	20	15	7	92	50	74	95	57	1 x 45°	112	27
4	65 - 80	75	182	17.5	33	45	220	75	150	24	18	10	130	70	96	125	80	1 x 45°	140	37
5	85 - 100	90	222	21	40	50	280	80	180	28	20	10	155	70	125	150	80	1 x 45°	172	40

Note: Dimensions [mm] without statement of tolerances in accordance with DIN 7168m.

Other dimensions are available on request.

*Dimension A is with the standard bush pressed in.

3.2 MINI SELF-ALIGNING BEARING HOUSINGS



MINI Bearing Housing

Design:

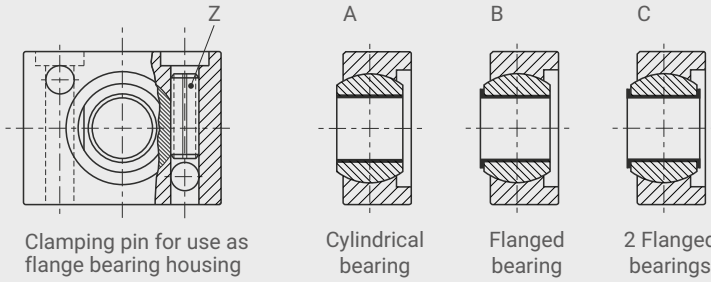

Clamping pin for use as flange bearing housing

Cylindrical bearing

Flanged bearing

2 Flanged bearings

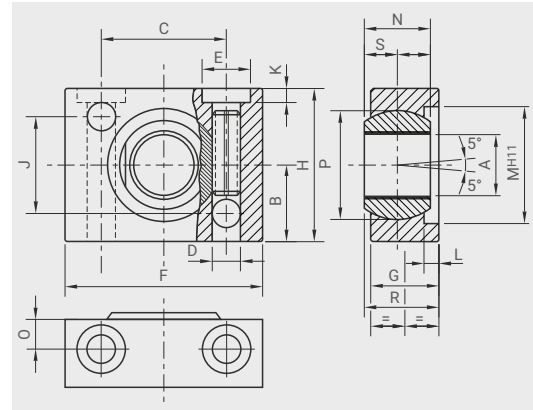

Housing material: AlMgSi12
Spherical insert material: 9SMn28K

Ordering example:

Size Design
MINI-0-8-BZ-DU — Bush product
Standard bush D_i — Clamping pin

DIMENSIONS [mm] MINI BEARING HOUSING

Size	Ø-range A*	B	C	D	E	F	G	H	J	K	L	M	N	O	P	R	S
0	8 - 15	17.5	28.5	6.4	10.5	45	15	35	22	3	2.5	26	15	6	25	16	7.5

Note: Dimensions [mm] without statement of tolerances in accordance with DIN 7168m.

Other dimensions are available on request.

*Dimension A is with the standard bush pressed in.

3.3 EXALIGN™ SELF-ALIGNING BEARING HOUSINGS



PB Plummer Block

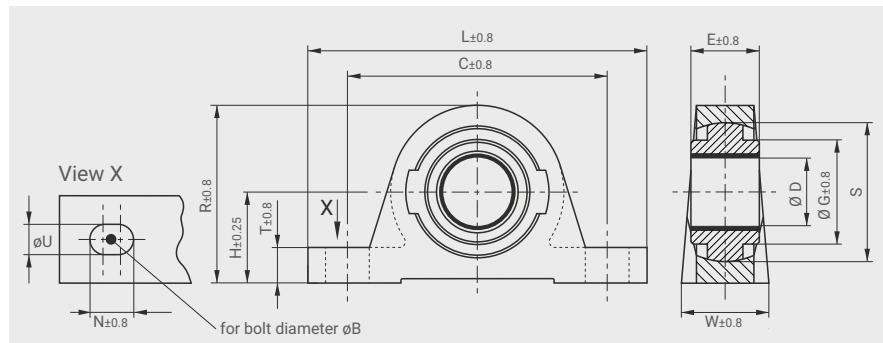
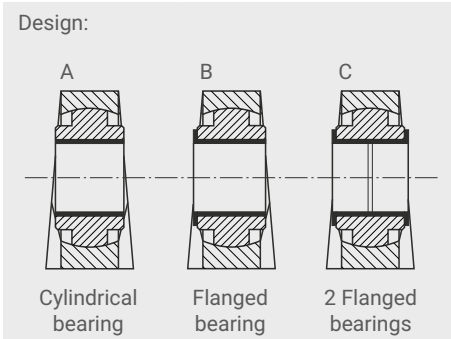

Housing material: GG 20

Spherical insert material: GG 20

Stainless and corrosion-resistant versions are available on request.

Ordering example:

Plummer block **PB1-10M-B-DU**

Size Standard bush ϕD

Plummer block	Size	Standard bush ϕD	Design (see sketch above)	Bush product for dry applications	with design	Bush product for greased applications	with design
PB1	M Metric	A	Cylindrical bearing	DP4®	A, B or C	DX®	A
PB2	E Inch	B	Flanged bearing	DP4-B	A, B or C	DX®10	A
PB3		C	2 Flanged bearings	DU®	A, B or C	HI-EX™	A
PB4				DU-B	A, B or C	DS	A
PB5				DP10	A, B or C	SY	A
PB6				DP11	A, B or C	GGB-SZ	A
PB7				DS	A		
PB8				GGB-CSM®	A		
PB9				GGB-CBM®	A		
PB10				GAR-MAX®	A (D>28mm)		
				GAR-FIL	A (D>28mm)		
				HPM	A (D>28mm)		
				HPF	A (D>28mm)		
				HSG	A (D>28mm)		
				HPMB®	A (D>28mm)		

ORDER-NO.	DIMENSIONS [mm] EXALIGN™ PB PLUMMER BLOCK													
GGB	D*	Insert bore H7	øU	øB	E	H	C	L	W	T	R	G	N	S
PB1-10M	10	12	9.5	8	15	28.6	76	102	25	10	56	33.3	13	41.2
PB1-12M	12	14	9.5	8	15	28.6	76	102	25	10	56	33.3	13	41.2
PB1-13M	13	15	9.5	8	15	28.6	76	102	25	10	56	33.3	13	41.2
PB1-14M	14	16	9.5	8	15	28.6	76	102	25	10	56	33.3	13	41.2
PB1-15M	15	17	9.5	8	15	28.6	76	102	25	10	56	33.3	13	41.2
PB1-16M	16	18	9.5	8	15	28.6	76	102	25	10	56	33.3	13	41.2
PB1-17M	17	19	9.5	8	15	28.6	76	102	25	10	56	33.3	13	41.2
PB1-18M	18	20	9.5	8	15	28.6	76	102	25	10	56	33.3	13	41.2
PB2-20M	20	23	11.1	10	20	33.3	95	124	32	13	65	39.7	16	50.7
PB2-22M	22	25	11.1	10	20	33.3	95	124	32	13	65	39.7	16	50.7
PB2-24M	24	27	11.1	10	20	33.3	95	124	32	13	65	39.7	16	50.7
PB2-25M	25	28	11.1	10	25	33.3	95	124	32	13	65	39.7	16	50.7
PB2-28M	28	32	14.3	12	30	41.3	122	159	41	16	81	51	22	63.4
PB3-30M	30	34	14.3	12	30	41.3	122	159	41	16	81	51	22	63.4
PB3-32M	32	36	14.3	12	30	41.3	122	159	41	16	81	51	22	63.4
PB4-35M	35	39	14.3	12	35	49.2	137	183	48	16	102	60.3	22	76.1
PB4-40M	40	44	14.3	12	40	49.2	137	183	48	16	102	60.3	22	76.1
PB5-45M	45	50	14.3	12	45	54	152	194	54	16	113	73	22	88.8
PB6-50M	50	55	17.5	16	50	61.9	168	214	57	19	122	79.3	22	100
PB7-55M	55	60	17.5	16	55	66.7	197	247	64	22	135	83	22	110
PB7-60M	60	65	17.5	16	60	66.7	197	247	64	22	135	83	22	110
PB7-65M	65	70	17.5	16	60	66.7	197	247	64	22	135	83	22	110
PB8-70M	70	75	17.5	16	65	71.4	200	254	70	25	143	89	22	120
PB8-75M	75	80	17.5	16	65	71.4	200	254	70	25	143	89	22	120
PB9-80M	80	85	22.2	20	80	87.3	235	295	89	32	175	108	27	139.7
PB9-85M	85	90	22.2	20	80	87.3	235	295	89	32	175	108	27	139.7
PB10-90M	90	95	22.2	20	80	101.6	279	330	102	32	206	130	30	170
PB10-95M	95	100	22.2	20	80	101.6	279	330	102	32	206	130	30	170
PB10-100M	100	105	22.2	20	80	101.6	279	330	102	32	206	130	30	170

Other dimensions are available on request.

*Dimension D is with the standard bush pressed in.

3.3 EXALIGN™ SELF-ALIGNING BEARING HOUSINGS



DF Flanged Bearing Housing - 2 Bolts

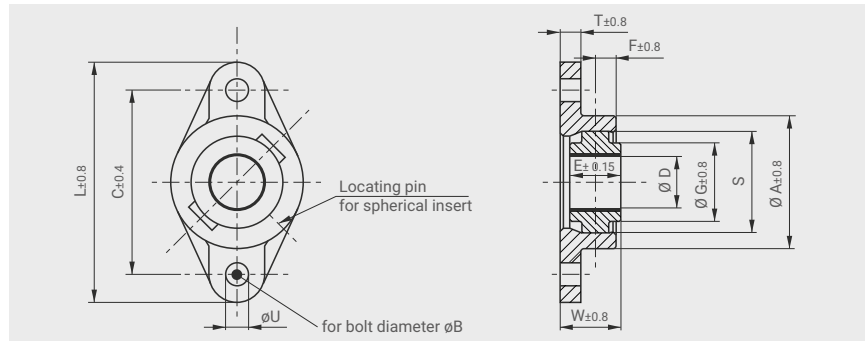
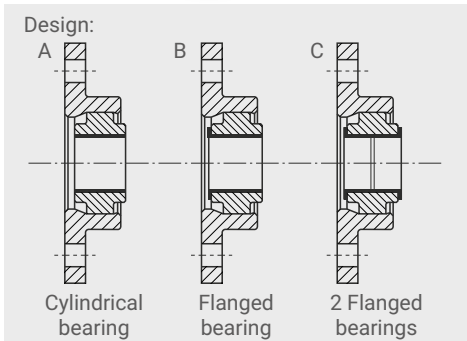

Housing material: GG 20

Spherical insert material: GG 20

Stainless and corrosion-resistant versions are available on request.

Ordering example:

Flanged housing — **DF1-10M-B-DU**

Size Standard bush Ø D

Flanged housing	Size	Standard bush Ø D	Design (see sketch above)	Bush product for dry applications	with design	Bush product for greased applications	with design
DF1	M Metric	A Cylindrical bearing	DP4®	A, B or C	DX®	A	
DF2	E Inch	B Flanged bearing	DP4-B	A, B or C	DX®10	A	
DF3		C 2 Flanged bearings	DU®	A, B or C	HI-EX™	A	
DF4			DU-B	A, B or C	DS	A	
DF5			DP10	A, B or C	SY	A	
DF6			DP11	A, B or C	GGB-SZ	A	
DF7			DS	A			
DF8			GGB-CSM®	A			
DF9			GGB-CBM®	A			
DF10			GAR-MAX®	A (D>28mm)			
			GAR-FIL	A (D>28mm)			
			HPM	A (D>28mm)			
			HPF	A (D>28mm)			
			HSG	A (D>28mm)			
			HPMB®	A (D>28mm)			

ORDER-NO.	DIMENSIONS [mm] EXALIGN™ DF FLANGED BEARING HOUSINGS												
GGB	D*	Insert bore H7	øU	øB	E	C	L	T	W	A	F	G	S
DF1-10M	10	12	9.5	8	15	81	103	8	23	54	6	33.3	41.2
DF1-12M	12	14	9.5	8	15	81	103	8	23	54	6	33.3	41.2
DF1-13M	13	15	9.5	8	15	81	103	8	23	54	6	33.3	41.2
DF1-14M	14	16	9.5	8	15	81	103	8	23	54	6	33.3	41.2
DF1-15M	15	17	9.5	8	15	81	103	8	23	54	6	33.3	41.2
DF1-16M	16	18	9.5	8	15	81	103	8	23	54	6	33.3	41.2
DF1-17M	17	19	9.5	8	15	81	103	8	23	54	6	33.3	41.2
DF1-18M	18	20	9.5	8	15	81	103	8	23	54	6	33.3	41.2
DF2-20M	20	23	11.1	10	20	89	116	10	27	64	10	39.7	50.7
DF2-22M	22	25	11.1	10	20	89	116	10	27	64	10	39.7	50.7
DF2-24M	24	27	11.1	10	20	89	116	10	27	64	10	39.7	50.7
DF2-25M	25	28	11.1	10	25	89	116	10	30	64	10	39.7	50.7
DF2-28M	28	32	14.3	12	30	113	143	11	36	79	13	51	63.4
DF3-30M	30	34	14.3	12	30	113	143	11	36	79	13	51	63.4
DF3-32M	32	36	14.3	12	30	113	143	11	36	79	13	51	63.4
DF4-35M	35	39	14.3	12	35	130	159	14	45	95	16	60.3	76.1
DF4-40M	40	44	14.3	12	40	130	159	14	45	95	16	60.3	76.1
DF5-45M	45	50	14.3	12	45	144	175	16	51	108	16	73	88.8
DF6-50M	50	55	17.5	16	50	157	190	16	58	117	21	79.3	100
DF7-55M	55	60	17.5	16	55	184	216	17	62	137	22	83	110
DF7-60M	60	65	17.5	16	60	184	216	17	65	137	22	83	110
DF7-65M	65	70	17.5	16	60	184	216	17	65	137	22	83	110
DF8-70M	70	75	17.5	16	65	202	236	19	71	143	25	89	120
DF8-75M	75	80	17.5	16	65	202	236	19	71	143	25	89	120
DF9-80M	80	85	22.2	20	80	214	259	22	28	117	129	108	139.7
DF9-85M	85	90	22.2	20	80	214	259	22	28	117	129	108	139.7
DF10-90M	90	95	22.2	20	80	279	324	25	91	210	32	130	170
DF10-95M	95	100	22.2	20	80	279	324	25	91	210	32	130	170
DF10-100M	100	105	22.2	20	80	279	324	25	91	210	32	130	170

Other dimensions are available on request.

*Dimension D is with the standard bush pressed in.

3.5 EXALIGN™ SELF-ALIGNING BEARING HOUSINGS



FL Flanged Bearing Housing - 4 Bolts

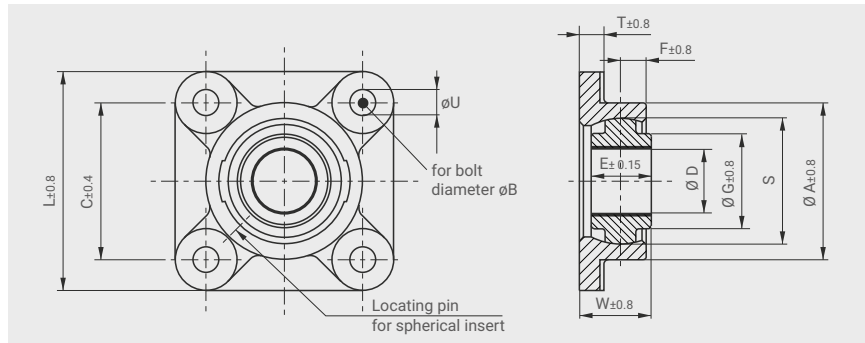
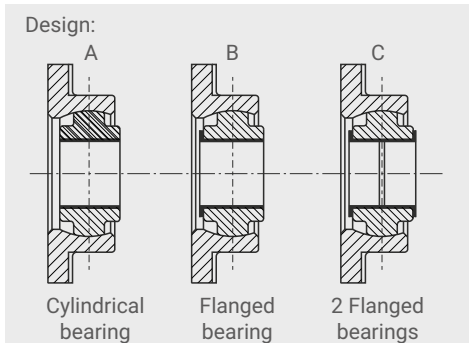

Housing material: GG 20

Spherical insert material: GG 20

Stainless and corrosion-resistant versions are available on request.

Ordering example:

Flanged housing — **FL1-10M-B-DU**

Size Standard bush $\varnothing D$

Flanged housing	Size	Standard bush $\varnothing D$	Design (see sketch above)	Bush product for dry applications	with design	Bush product for greased applications	with design
FL1	M	Metric	A Cylindrical bearing	DP4®	A, B or C	DX®	A
FL2	E	Inch	B Flanged bearing	DP4-B	A, B or C	DX®10	A
FL3			C 2 Flanged bearings	DU®	A, B or C	HI-EX™	A
FL4				DU-B	A, B or C	DS	A
FL5				DP10	A, B or C	SY	A
FL6				DP11	A, B or C	GGB-SZ	A
FL7				DS	A		
FL8				GGB-CSM®	A		
FL9				GGB-CBM®	A		
FL10				GAR-MAX®	A (D>28mm)		
				GAR-FIL	A (D>28mm)		
				HPM	A (D>28mm)		
				HPF	A (D>28mm)		
				HSG	A (D>28mm)		
				HPMB®	A (D>28mm)		

ORDER-NO.	DIMENSIONS [mm] EXALIGN™ FL FLANGED BEARING HOUSINGS												
GGB	D*	Insert bore H7	øU	øB	E	C	L	T	W	A	F	G	S
FL1-10M	10	12	9.5	8	15	57	76	8	23	54	6	33.3	41.2
FL1-12M	12	14	9.5	8	15	57	76	8	23	54	6	33.3	41.2
FL1-13M	13	15	9.5	8	15	57	76	8	23	54	6	33.3	41.2
FL1-14M	14	16	9.5	8	15	57	76	8	23	54	6	33.3	41.2
FL1-15M	15	17	9.5	8	15	57	76	8	23	54	6	33.3	41.2
FL1-16M	16	18	9.5	8	15	57	76	8	23	54	6	33.3	41.2
FL1-17M	17	19	9.5	8	15	57	76	8	23	54	6	33.3	41.2
FL1-18M	18	20	9.5	8	15	57	76	8	23	54	6	33.3	41.2
FL2-20M	20	23	11.1	10	20	64	89	10	27	64	10	39.7	50.7
FL2-22M	22	25	11.1	10	20	64	89	10	27	64	10	39.7	50.7
FL2-24M	24	27	11.1	10	20	64	89	10	27	64	10	39.7	50.7
FL2-25M	25	28	11.1	10	25	64	89	10	30	64	10	39.7	50.7
FL2-28M	28	32	14.3	12	30	79	110	11	36	79	13	51	63.4
FL3-30M	30	34	14.3	12	30	79	110	11	36	79	13	51	63.4
FL3-32M	32	36	14.3	12	30	79	110	11	36	79	13	51	63.4
FL4-35M	35	39	14.3	12	35	92	121	14	45	95	16	60.3	76.1
FL4-40M	40	44	14.3	12	40	92	121	14	45	95	16	60.3	76.1
FL5-45M	45	50	14.3	12	45	102	133	16	51	108	16	73	88.8
FL6-50M	50	55	17.5	16	50	111	143	16	58	117	21	79.3	100
FL7-55M	55	60	17.5	16	55	130	165	17	62	137	22	83	110
FL7-60M	60	65	17.5	16	60	130	165	17	65	137	22	83	110
FL7-65M	65	70	17.5	16	60	130	165	17	65	137	22	83	110
FL8-70M	70	75	17.5	16	65	143	175	19	71	143	25	89	120
FL8-75M	75	80	17.5	16	65	143	175	19	71	143	25	89	120
FL9-80M	80	85	22.2	20	80	152	197	22	28	117	129	108	139.7
FL9-85M	85	90	22.2	20	80	152	197	22	28	117	129	108	139.7
FL10-90M	90	95	22.2	20	80	197	241	25	91	210	32	130	170
FL10-95M	95	100	22.2	20	80	197	241	25	91	210	32	130	170
FL10-100M	100	105	22.2	20	80	197	241	25	91	210	32	130	170

Other dimensions are available on request.

*Dimension D is with the standard bush pressed in.

4 Lubrication

Re-greasing will significantly increase the life of grease lubricated bearings such as GGB DX.

Lubrication between the outer housing and inner spherical will reduce friction, thus aiding assembly, and may prevent fretting corrosion that can occur with repeated movement.

In general, the standard housings are not recommended for applications with dynamic angular movement. Under these conditions, it is necessary to provide a low friction bearing surface between the outer housing and the inner spherical in order to minimise static friction effects and consequential edge loading of the inner bearing bush.

All standard bearing housings are supplied with an initial lubrication of the spherical self-aligning surfaces using a long-life grease.

Where a greased bearing is fitted it is required to periodically relubricate the bearing in-situ, the recommended option is through a shaft drilling as shown on the right.

If this is not possible, the UNI, MINI and EXALIGN™ housings can be supplied with a standard grease nipple on request - see figure below.

If a grease nipple is fitted, greasing is best carried out when the lubricant drilling through the outer housing is in line with the drilling through the inner spherical. However, a certain amount of angular misalignment is acceptable when grease will penetrate and adequately lubricate the bearing surface. The maximum angles of misalignment for EXALIGN™ bearings are given in the following table. If these angles are exceeded, the misalignment of grease holes in the inner and outer housings will prevent lubricant reaching the bearing surface.

The greasing option for UNI bearing housings will depend on the bearing application.

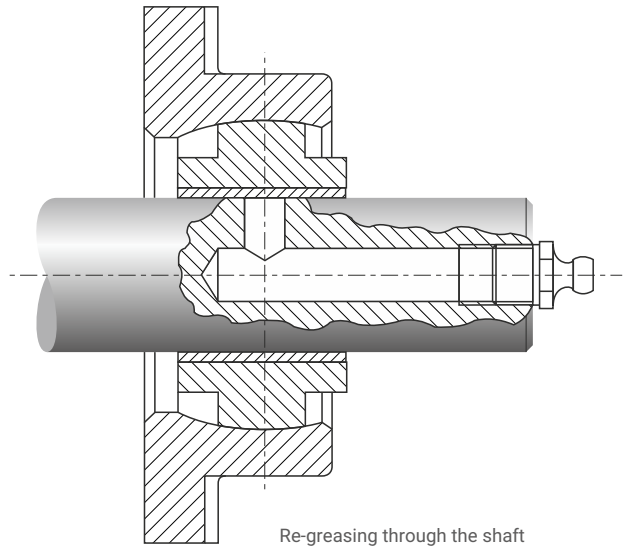

EXALIGN BEARING SIZE	MAXIMUM ANGLE (a) FOR OPTIMUM DISTRIBUTION OF LUBRICANT
1	± 4.5°
2	± 4.0°
3	± 3.0°
4 - 7	± 2.5°
8 - 9	± 2.0°
10	± 1.5°

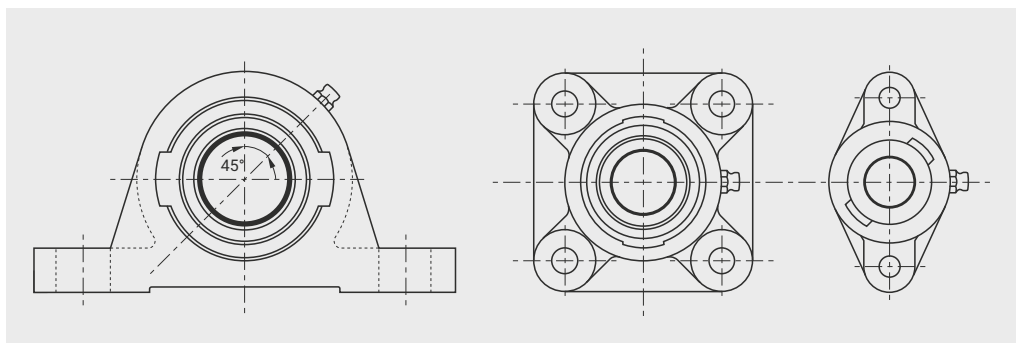

Typical arrangement of grease nipples in EXALIGN™ bearing housings

5 Applications

Potential applications for GGB self-aligning bearing housings include:

- Wind energy
- Car washing machines
- Cleaning machines
- Drum systems
- Bevelling equipment
- Handling systems
- Conveyor belts (pulleys)
- Printing machines
- Heating and ventilation equipment
- Hoists
- Cranes
- Textile machinery
- Special machines
- Bakery equipment
- Marine equipment.

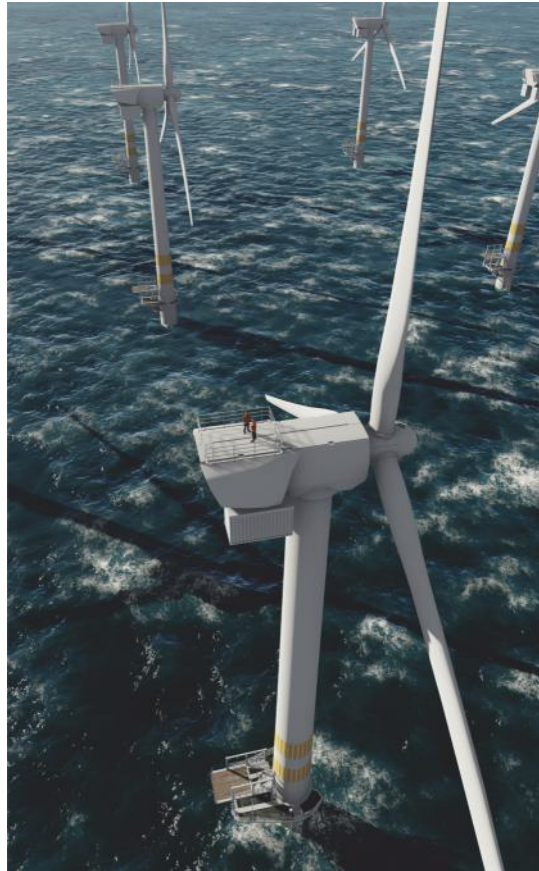

6 Bearing Application Data Sheet

Not sure which GGB part fits your application requirements?

Please complete the form below and share it with your GGB sales person or distributor representative.

DATA FOR BEARING DESIGN CALCULATION

New Design Existing Design

Application: _____

Project/No.: _____ Quantity: _____

DIMENSIONS [mm]

Inside diameter	D_i
Outside diameter	D_o
Length	B
Outer ring length	B_F
Flange Diameter	D_{fl}
Flange thickness	B_{fl}
Wall thickness	S_T
Length of slideplate	L
Width of slideplate	W
Thickness of slideplate	S_s

LOAD

- Static load
 Dynamic load

Axial load F	[N]
Radial load F	[N]

MOVEMENT

Rotational speed	N [1/min]
Speed	U [m/s]
Length of stroke	L_s [mm]
Frequency of stroke	[1/min]
Oscillating cycle	ϕ [°]
Osc. frequency	N_{osz} [1/min]

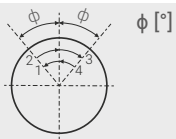

MATING SURFACE

Material	
Hardness	HB/HRC
Surface finish	Ra [μm]

FITS & TOLERANCES

Shaft	D_J
Bearing housing	D_H

OPERATING ENVIRONMENT

Ambient temperature	T_{amb} [°]
Bearing housing material	

- Housing with good heating transfer properties
 Light pressing or insulated housing with poor heat transfer properties
 Non metal housing with poor heat transfer properties
 Alternate operation in water and dry

LUBRICATION

- Dry
 Continuous lubrication
 Process fluid lubrication
 Initial lubrication only
 Hydrodynamic conditions

Process fluid	
Lubricant	
Dynamic viscosity	η [mPas]

SERVICE HOURS PER DAY

Continuous operation	
Intermittent operation	
Operating time	
Days per year	

SERVICE LIFE

Required service life	L_H [h]
-----------------------	-----------

BEARING TYPE

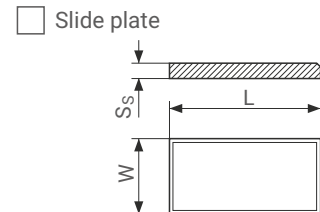
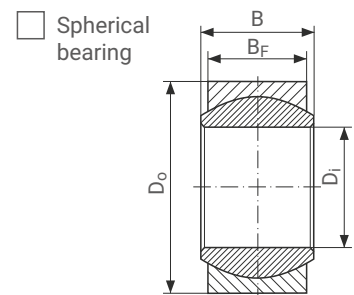
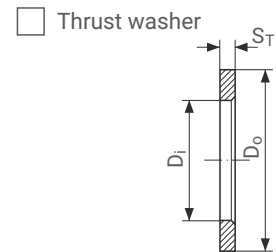
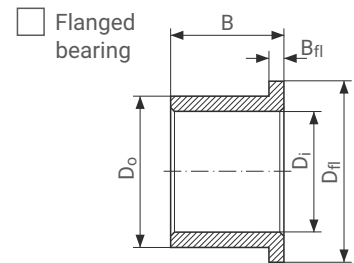
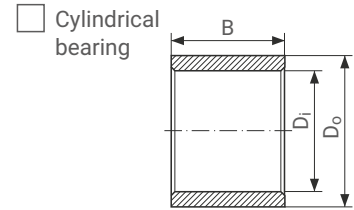

- Special parts (sketch)
 Steady load
 Rotating load
 Rotational movement
 Oscillating movement
 Linear movement

CUSTOMER INFORMATION

Company _____

Street _____

City / State / Province / Post Code _____

Telephone _____ Fax _____

Name _____

Email Address _____ Date _____

7 Product Information

GGB assures the products described in this document have no manufacturing errors or material deficiencies.

The details set out in this document are registered to assist in assessing material suitability for intended use. They have been developed from our own investigations as well as generally accessible publications. They do not represent any assurance for the properties themselves.

Unless expressly declared in writing, GGB gives no warranty that the products described are suited for any particular purpose or specific operating circumstances. GGB accepts no liability for any losses, damages, or costs however they may arise through direct or indirect use of these products.

GGB's sales and delivery terms and conditions, included as an integral part of quotations, stock and price lists, apply absolutely to all business conducted by GGB. Copies can be made available on request.

Products are subject to continual development. GGB retains the right to make specification amendments or improvements to technical data without prior announcement. Edition 2023 (this edition replaces earlier editions which hereby lose their validity).

STATEMENT REGARDING LEAD CONTENT IN GGB PRODUCTS & EU DIRECTIVE COMPLIANCE

GGB is committed to adhering to all U.S., European, and international standards and regulations with regard to lead content. We have established internal processes that monitor any changes to existing standards and regulations, and we work collaboratively with customers and distributors to ensure all requirements are strictly followed. This includes RoHS and REACH guidelines.

GGB makes it a top priority to operate in an environmentally conscious and safe manner. We follow numerous industry best practices and are committed to meeting or exceeding a variety of internationally recognized standards for emissions control and workplace safety.

Each of our global locations has management systems in place that adhere to IATF 16949, ISO 9001, ISO 14001, ISO 45001, and AS9100D/EN9100 quality regulations.

All of our certificates can be found here: <https://www.ggbearings.com/en/certificates>. A detailed explanation of our commitment to REACH and RoHS directives can be found at:

<https://www.ggbearings.com/en/who-we-are/quality-and-environment>.

GGB®, DU®, DX®, GGB-DB®, UNI, MINI and EXALIGN™ are registered trademarks or trademarks, as the case may be, of GGB and its affiliates.

©2023 GGB. All rights reserved.

PUSHING BOUNDARIES TO CO-CREATE A HIGHER QUALITY OF LIFE



Standard- und Sondergleitlager beziehen über
www.caspar-gleitlager.de



IN119ENG03-23USA